

Technical Document

- [Tools Information](#)
- [FAQs](#)
- [Application Note](#)
 - [HA0002E Reading Larger than Usual MCU Tables](#)
 - [HA0007E Using the MCU Look Up Table Instructions](#)
 - [HA0011E HT48 & HT46 Keyboard Scan Program](#)
 - [HA0019E Using the Watchdog Timer in the HT48 MCU Series](#)
 - [HA0020E Using the Timer/Event Counter in the HT48 MCU Series](#)

Features

- Operating voltage:
 - $f_{SYS}=32768\text{Hz}$: 2.2V~5.5V
 - $f_{SYS}=4\text{MHz}$: 2.2V~5.5V
 - $f_{SYS}=8\text{MHz}$: 3.3V~5.5V
- 2k×14 program memory ROM
- 88×8 data memory RAM
- 8 bidirectional I/O lines
- Max. 16×16 LED driver output
- 8 LED shared I/O lines
- 24 LED shared output
- One external interrupt input
- One internal interrupt
- 8 bit programmable timer/event counter
- 4-level subroutine nesting
- Watchdog Timer (WDT)
- Low voltage reset (LVR)
- External RC and 32768Hz crystal oscillator
- Dual clock system offers three operating modes
 - Normal mode: Both RC and 32768Hz clock active
 - Slow mode: 32768Hz clock only
 - Idle mode: Periodical wake-up by watchdog timer overflow
- HALT function and wake-up feature reduce power consumption
- 14-bit table read instructions
- 63 powerful instructions
- One instruction cycle: 4 system clock periods
- All instructions in 1 or 2 instruction cycles
- Bit manipulation instructions
- Up to 0.5 μs instruction cycle with 8MHz system clock
- 44/52-pin QFP and 44-pin LQFP packages

General Description

This device is an 8-bit high performance, RISC architecture microcontroller specifically designed for multiple I/O control product applications. The advantages of low power consumption, I/O flexibility, timer functions, oscillator options, HALT and wake-up functions, watchdog

timer, as well as low cost, enhance the versatility of these devices to suit a wide range of application possibilities such as industrial control, consumer products, subsystem controllers, etc.

Block Diagram

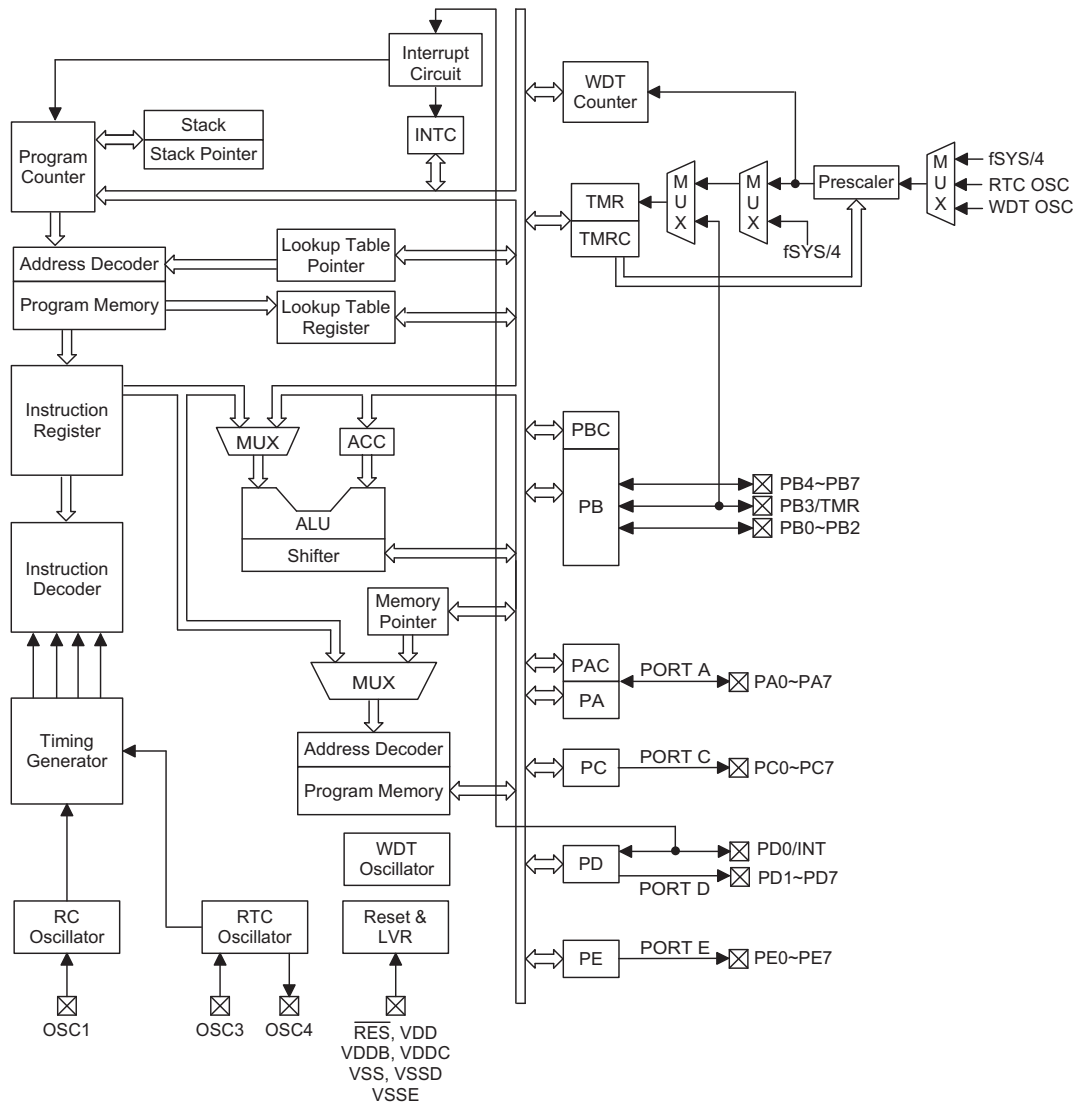

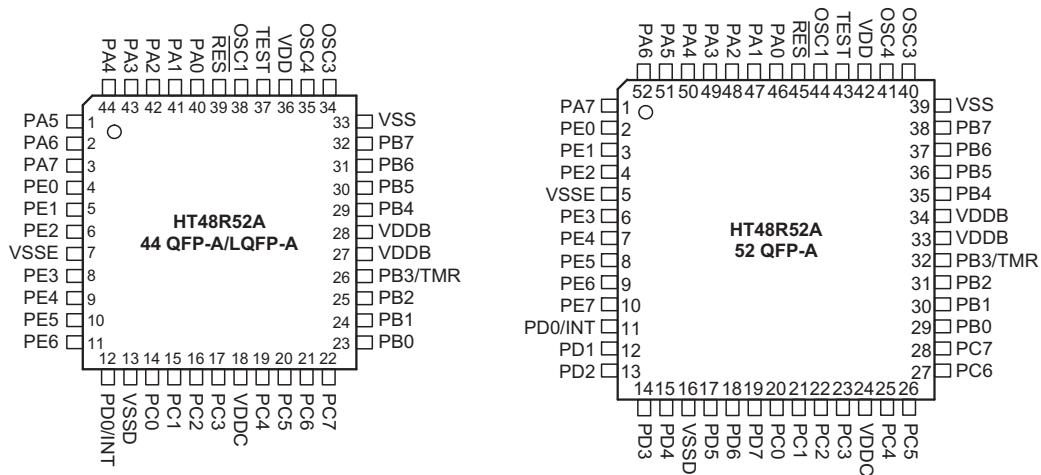
Pin Assignment

Pin Description

Pin Name	I/O	Options	Description
PA0~PA7	I/O	Pull-high Wake-up	Bidirectional 8-bit input/output port. Software instructions determine if the pin is a CMOS output or Schmitt trigger input. A pull-high resistor can be connected via configuration option. Each pin can be setup to be a wake-up input via configuration options.
PB0~PB2, PB3/TMR PB4~PB7	I/O	—	Bidirectional 8-bit input/output port. The timer input is pin-shared with PB3.
PC0~PC7	O	—	PC0~PC7 are PMOS output pins.
PD0/INT	I/O	—	External interrupt input. Pin-shared with PD0 and activated on a high to low or low to high transition. PD0 is NMOS type output pin.
PD1~PD7	O	—	PD1~PD7 are NMOS output pins.
PE0~PE7	O	—	PE0~PE7 are NMOS output pins.
$\overline{\text{RES}}$	I	—	Schmitt trigger reset input. Active low.
OSC1	I	—	OSC1 is connected to a external resistor for the internal system clock.
OSC3 OSC4	I O	—	Real time clock oscillator. OSC3 and OSC4 are connected to a 32768Hz crystal oscillator for system clock timing purposes.
TEST	I	—	TEST pin is internally pulled-high and can be left floating. For test only.
VDD	—	—	Positive power supply
VDDDB	—	—	PB port positive power supply
VDDC	—	—	PC port positive power supply
VSS	—	—	Negative Power supply, ground
VSSD, VSSE	—	—	PD & PE port negative power supply, ground

Absolute Maximum Ratings

Supply Voltage	$V_{SS}-0.3V$ to $V_{SS}+6.0V$	Storage Temperature	$-50^{\circ}C$ to $125^{\circ}C$
Input Voltage	$V_{SS}-0.3V$ to $V_{DD}+0.3V$	Operating Temperature	$-40^{\circ}C$ to $85^{\circ}C$
I_{OL} Total	300mA	I_{OH} Total	-200mA
Total Power Dissipation	500mW		

Note: These are stress ratings only. Stresses exceeding the range specified under "Absolute Maximum Ratings" may cause substantial damage to the device. Functional operation of this device at other conditions beyond those listed in the specification is not implied and prolonged exposure to extreme conditions may affect device reliability.

D.C. Characteristics
 $T_a=25^{\circ}C$

Symbol	Parameter	Test Conditions		Min.	Typ.	Max.	Unit
		V_{DD}	Conditions				
V_{DD}	Operating Voltage	—	$f_{SYS}=4MHz$	2.2	—	5.5	V
		—	$f_{SYS}=8MHz$	3.3	—	5.5	
		—	$f_{SYS}=32768Hz$	2.2	—	5.5	
I_{DD1}	Operating Current (RC OSC)	3V	No load, $f_{SYS}=4MHz$	—	1.2	2	mA
		5V		—	2.5	5	
I_{DD2}	Operating Current (RC OSC)	5V	No load, $f_{SYS}=8MHz$	—	4	8	mA
I_{DD3}	Operating Current (*RTC OSC Enabled, RC OSC Disabled)	3V	No load, $f_{SYS}=32768Hz$	—	20	40	μA
		5V		—	50	100	
I_{STB1}	Standby Current (WDT OSC, *RTC OSC Enabled)	3V	No load, system HALT	—	3	5	μA
		5V		—	6	10	
I_{STB2}	Standby Current (WDT OSC Disabled, *RTC OSC Enabled)	3V	No load, system HALT	—	1	2	μA
		5V		—	2	4	
I_{STB3}	Standby Current (WDT OSC Enabled, RTC OSC Disabled)	3V	No load, system HALT	—	2	4	μA
		5V		—	4	8	
I_{STB4}	Standby Current (WDT OSC, RTC OSC Disabled)	3V	No load, system HALT	—	—	1	μA
		5V		—	—	2	
V_{IL1}	Input Low Voltage for I/O Ports	—	—	0	—	$0.3V_{DD}$	V
V_{IH1}	Input High Voltage for I/O Ports	—	—	$0.7V_{DD}$	—	V_{DD}	V
V_{IL2}	Input Low Voltage (\overline{RES})	—	—	0	—	$0.4V_{DD}$	V
V_{IH2}	Input High Voltage (\overline{RES})	—	—	$0.9V_{DD}$	—	V_{DD}	V
V_{LVR}	Low Voltage Reset	—	3.3V option	2.7	3	3.3	V
I_{OL1}	I/O Port Sink Current for PA	3V	$V_{OL}=0.1V_{DD}$	4	8	—	mA
		5V		10	20	—	
I_{OL2}	I/O Port Sink Current for PD, PE	3V	$V_{OL}=0.1V_{DD}$	8	16	—	mA
		5V		20	40	—	
I_{OH1}	I/O Port Source Current for PA	3V	$V_{OH}=0.9V_{DD}$	-2	-4	—	mA
		5V		-5	-10	—	

Symbol	Parameter	Test Conditions		Min.	Typ.	Max.	Unit
		V _{DD}	Conditions				
I _{OH2}	I/O Port Source Current for PB, PC	3V	V _{OH} =0.9V _{DD}	-4	-8	—	mA
		5V		-10	-20	—	
R _{PH}	Pull-high Resistance	3V	—	20	60	100	kΩ
		5V		10	30	50	

Note: * RTC OSC in slow start oscillating

A.C. Characteristics

T_a=25°C

Symbol	Parameter	Test Conditions		Min.	Typ.	Max.	Unit
		V _{DD}	Conditions				
f _{SYS}	System Clock (RC OSC)	—	2.2V~5.5V	400	—	4000	kHz
		—	3.3V~5.5V	400	—	8000	
f _{TIMER}	Timer I/P Frequency	—	2.2V~5.5V	0	—	4000	kHz
		—	3.3V~5.5V	0	—	8000	
t _{WDTOSC}	Watchdog Oscillator Period	3V	—	45	90	180	μs
		5V	—	32	65	130	μs
t _{FSP1}	f _{SP} Time-out Period Clock Source from WDT	3V	With prescaler (f _S /4096)	184	369	737	ms
		5V		131	266	532	
t _{FSP2}	f _{SP} Time-out Period Clock Source from RTC Oscillator	3V	With prescaler (f _S /4096)	—	125	—	ms
		5V		—	125	—	
t _{RES}	External Reset Low Pulse Width	—	—	1	—	—	μs
t _{SST}	System Start-up Timer Period	—	Power-up or wake-up from HALT	—	1024	—	t _{SYS}
t _{LVR}	Low Voltage Width to Reset	—	—	0.25	1	2	ms
t _{INT}	Interrupt Pulse Width	—	—	1	—	—	μs

Note: t_{SYS}=1/f_{SYS}

Functional Description

Execution Flow

The system clock for the microcontroller is derived from either an RC oscillator or a RTC oscillator. The system clock is internally divided into four non-overlapping clocks. One instruction cycle consists of four system clock cycles.

Instruction fetching and execution are pipelined in such a way that a fetch takes an instruction cycle while decoding and execution takes the next instruction cycle. However, the pipelining scheme causes each instruction to be effectively executed in a cycle. If an instruction changes the program counter, two cycles are required to complete the instruction.

Program Counter – PC

The program counter (PC) controls the sequence in which the instructions stored in the program ROM are executed and its contents specify a full range of program memory.

After accessing a program memory word to fetch an instruction code, the contents of the program counter are

incremented by one. The program counter then points to the memory word containing the next instruction code.

When executing a jump instruction, conditional skip execution, loading PCL register, subroutine call or return from subroutine, initial reset, internal interrupt, external interrupt or return from interrupt, the PC manipulates the program transfer by loading the address corresponding to each instruction.

The conditional skip is activated by instructions. Once the condition is met, the next instruction, fetched during the current instruction execution, is discarded and a dummy cycle replaces it to get the proper instruction. Otherwise proceed with the next instruction.

The lower byte of the program counter (PCL) is a readable and writeable register (06H). Moving data into the PCL performs a short jump. The destination will be within 256 locations.

When a control transfer takes place, an additional dummy cycle is required.

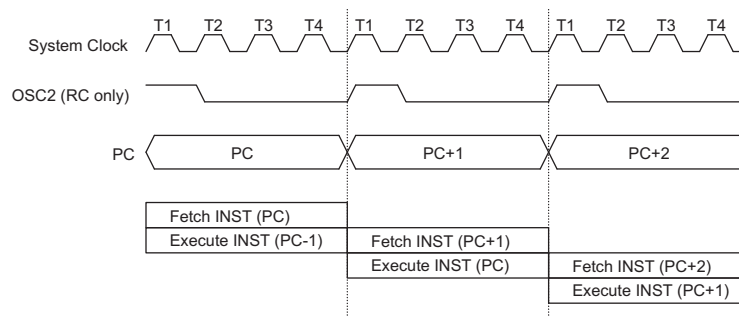

Execution Flow

Mode	Program Counter										
	*10	*9	*8	*7	*6	*5	*4	*3	*2	*1	*0
Initial Reset	0	0	0	0	0	0	0	0	0	0	0
External Interrupt	0	0	0	0	0	0	0	0	1	0	0
Timer/Event Counter Overflow	0	0	0	0	0	0	0	1	0	0	0
Skip	Program Counter+2										
Loading PCL	*10	*9	*8	@7	@6	@5	@4	@3	@2	@1	@0
Jump, Call Branch	#10	#9	#8	#7	#6	#5	#4	#3	#2	#1	#0
Return from Subroutine	S10	S9	S8	S7	S6	S5	S4	S3	S2	S1	S0

Program Counter

Note: *10~*0: Program counter bits
#10~#0: Instruction code bits

S10~S0: Stack register bits
@7~@0: PCL bits

Program Memory – ROM

The program memory is used to store the program instructions which are to be executed. It also contains data, table, and interrupt entries, and is organized into 2048×14 bits, addressed by the program counter and table pointer.

Certain locations in the program memory are reserved for special usage:

- Location 000H
This area is reserved for program initialisation. After a chip reset, the program always begins execution at location 000H.
- Location 004H
This area is reserved for the external interrupt service program. If the INT input pin is activated, the interrupt is enabled and the stack is not full, the program begins execution at location 004H.
- Location 008H
This area is reserved for the timer/event counter interrupt service program. If a timer interrupt results from a timer/event counter overflow, and if the interrupt is enabled and the stack is not full, the program begins execution at location 008H .
- Table location
Any location in the program memory space can be used as look-up tables. The instructions "TABRDC [m]" (the current page, one page=256 words) and "TABRDL [m]" (the last page) transfer the contents of the lower-order byte to the specified data memory, and the higher-order byte to TBLH (08H). Only the destination of the lower-order byte in the table is well-defined, the other bits of the table word are transferred to the lower portion of the TBLH, and the remaining 2-bit words are read as "0". The Table Higher-order byte register (TBLH) is read only. The table pointer (TBLP) is a read/write register (07H), which indicates the table location. Before accessing the table, the location must be placed in the TBLP. The TBLH is read only and cannot be restored. If the main routine and the ISR (Interrupt Service Routine) both employ the table read instruction, the contents of the TBLH in the main routine are likely to be changed by the table read instruction used in the ISR, therefore errors may occur. In other words, using the table read

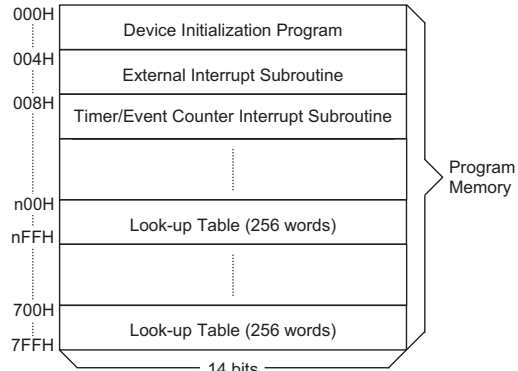

Note: n ranges from 0 to 7

Program Memory

instruction in the main routine and the ISR simultaneously should be avoided. However, if the table read instruction has to be applied in both the main routine and the ISR, the interrupt should be disabled prior to using the table read instruction. It should not be enabled until the TBLH has been backed up. All table related instructions require two cycles to complete the operation. These areas may function as normal program memory depending upon the requirements.

Stack Register – STACK

This is a special part of the memory which is used to save the contents of the program counter only. The stack is organized into 4 levels and is neither part of the data nor part of the program space, and is neither readable nor writeable. The activated level is indexed by the stack pointer (SP) and is neither readable nor writeable. At a subroutine call or interrupt acknowledge signal, the contents of the program counter are pushed onto the stack. At the end of a subroutine or an interrupt routine, signaled by a return instruction, RET or RETI, the program counter is restored to its previous value from the stack. After a chip reset, the stack pointer will point to the top of the stack.

If the stack is full and a non-masked interrupt takes place, the interrupt request flag will be recorded but the acknowledge signal will be inhibited. When the stack pointer is decremented, by RET or RETI, the interrupt will be serviced. This feature prevents stack overflow allowing the programmer to use the structure more easily. In a similar case, if the stack is full and a "CALL" is

Instruction	Table Location										
	*10	*9	*8	*7	*6	*5	*4	*3	*2	*1	*0
TABRDC [m]	P10	P9	P8	@7	@6	@5	@4	@3	@2	@1	@0
TABRDL [m]	1	1	1	@7	@6	@5	@4	@3	@2	@1	@0

Table Location

Note: *10~*0: Table location bits

P10~P8: Current program counter bits

@7~@0: Table pointer bits

subsequently executed, a stack overflow occurs and the first entry will be lost. Only the most recent 4 return addresses are stored.

Data Memory – RAM

The data memory has a capacity of 108×8 bits. The data memory is divided into two functional groups, namely, function registers and general purpose data memory (88×8). Most are read/write, but some are read only.

All of the data memory areas can handle arithmetic, logic, increment, decrement and rotate operations directly. Except for some dedicated bits, each bit in the data memory can be set and reset by "SET [m].i" and "CLR [m].i". They are also indirectly accessible through the memory pointer registers.

Indirect Addressing Register

Location 00H and 02H are indirect addressing registers that are not physically implemented. Any read/write operation of [00H] ([02H]) will access the data memory pointed to by MP0 (MP1). Reading location 00H (02H) itself indirectly will return the result "00H". Writing indirectly results in no operation.

The memory pointer registers, MP0 and MP1, are 7-bit registers.

Accumulator

The accumulator is closely related to ALU operations. It is also mapped to location 05H of the data memory and can carry out immediate data operations. The data movement between two data memory locations must pass through the accumulator.

Arithmetic and logic unit – ALU

This circuit performs 8-bit arithmetic and logic operations. The ALU provides the following functions:

- Arithmetic operations (ADD, ADC, SUB, SBC, DAA)
- Logic operations (AND, OR, XOR, CPL)
- Rotation (RL, RR, RLC, RRC)
- Increment and Decrement (INC, DEC)
- Branch decision (SZ, SNZ, SIZ, SDZ)

The ALU not only saves the results of a data operation but also changes the status register.

Status Register – STATUS

This 8-bit register (0AH) contains the zero flag (Z), carry flag (C), auxiliary carry flag (AC), overflow flag (OV), power down flag (PDF), and watchdog time-out flag (TO). It also records the status information and controls the operation sequence.

With the exception of the TO and PDF flags, bits in the status register can be altered by instructions like most other registers. Any data written into the status

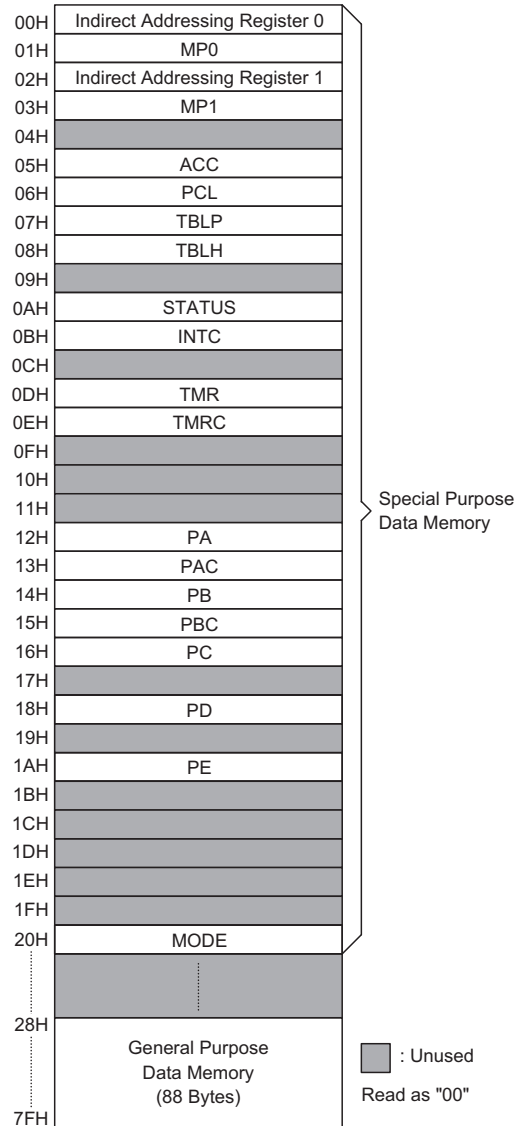

RAM Mapping

register will not change the TO or PDF flag. In addition, operations related to the status register may give different results from those intended. The TO flag can be affected only by a system power-up, a WDT time-out or executing the "CLR WDT" or "HALT" instruction. The PDF flag can be affected only by executing the "HALT" or "CLR WDT" instruction or during a system power-up.

The Z, OV, AC and C flags generally reflect the status of the latest operations.

In addition, on entering the interrupt sequence or executing the subroutine call, the status register will not be automatically pushed onto the stack. If the contents of the status register are important and if the subroutine can corrupt the status register, precautions must be taken to save it properly.

Bit No.	Label	Function
0	C	C is set if an operation results in a carry during an addition operation or if a borrow does not take place during a subtraction operation, otherwise C is cleared. C is also affected by a rotate through carry instruction.
1	AC	AC is set if an operation results in a carry out of the low nibbles in addition or no borrow from the high nibble into the low nibble in subtraction, otherwise AC is cleared.
2	Z	Z is set if the result of an arithmetic or logic operation is zero, otherwise Z is cleared.
3	OV	OV is set if an operation results in a carry into the highest-order bit but not a carry out of the highest-order bit, or vice versa, otherwise OV is cleared.
4	PDF	PDF is cleared by system power-up or executing the "CLR WDT" instruction. PDF is set by executing the "HALT" instruction.
5	TO	TO is cleared by a system power-up or executing the "CLR WDT" or "HALT" instruction. TO is set by a WDT time-out.
6, 7	—	Unused bit, read as "0"

STATUS (0AH) Register

Interrupt

The device provides an external interrupt and internal timer/event counter interrupt. The Interrupt Control Register (INTC;0BH) contains the interrupt control bits to set the enable or disable bits and the interrupt request flags.

Once an interrupt subroutine is serviced, all the other interrupts will be blocked (by clearing the EMI bit). This scheme may prevent any further interrupt nesting. Other interrupt requests may occur during this interval but only the interrupt request flag is recorded. If a certain interrupt requires servicing within the service routine, the EMI bit and the corresponding bit of the INTC may be set to allow interrupt nesting. If the stack is full, the interrupt request will not be acknowledged, even if the related interrupt is enabled, until the SP is decremented. If immediate service is desired, the stack must be prevented from becoming full.

All interrupts have a wake-up capability. When an interrupt is serviced, a control transfer occurs by pushing the program counter onto the stack, followed by a branch to a subroutine at specified location in the program memory. Only the program counter is pushed onto the stack. If the contents of the register or status register are altered by the interrupt service program, an action which may corrupt the desired control sequence, the contents should be saved in advance.

An external interrupt is triggered either on a high to low or low to high transition on the INT pin. The related interrupt request flag, EIF; bit 4 of the INTC register will then be set. When the interrupt is enabled, the stack is not full and the external interrupt is active, a subroutine call to location 04H will occur. The interrupt request flag (EIF) and EMI bits will be cleared to disable other interrupts.

The internal timer/event counter interrupt is initialised by setting the timer/event counter interrupt request flag, TF; bit 5 of the INTC register. This will be caused by a timer overflow. When the interrupt is enabled, the stack is not full and the TF bit is set, a subroutine call to location 08H will occur. The related interrupt request flag, TF, will then be reset and the EMI bit cleared to disable further interrupts.

During the execution of an interrupt subroutine, other interrupt acknowledge signals are held until the "RETI" instruction is executed or the EMI bit and the related interrupt control bit are set to 1, if the stack is not full. To return from the interrupt subroutine, a "RET" or "RETI" instruction may be invoked. RETI will set the EMI bit to enable an interrupt service, but RET will not.

Bit No.	Label	Function
0	EMI	Controls the master (global) interrupt (1=enable; 0=disable)
1	E EI	Controls the external interrupt (1=enable; 0=disable)
2	ETI	Controls the Timer/Event Counter 0 interrupt (1=enable; 0=disable)
3, 6, 7	—	Unused bit, read as "0"
4	EIF	External interrupt request flag (1=active; 0=inactive)
5	TF	Internal Timer/Event Counter 0 request flag (1=active; 0=inactive)

INTC (0BH) Register

Interrupts, occurring in the interval between the rising edges of two consecutive T2 pulses, will be serviced on the latter of the two T2 pulses, if the corresponding interrupts are enabled. In the case of simultaneous requests the following table shows the priority that is applied. These can be masked by resetting the EMI bit.

Interrupt Source	Priority	Vector
External Interrupt	1	04H
Timer/Event Counter Overflow	2	08H

The timer/event counter interrupt request flag, TF, external interrupt request flag, EIF, enable timer/event counter interrupt bit, ET, enable external interrupt bit, EEI, and enable master interrupt bit, EMI, constitute an interrupt control register, INTC, which is located at 0BH in the data memory. EMI, EEI, ETI are used to control the enabling/disabling of interrupts. These bits prevent the requested interrupt from being serviced. Once the interrupt request flags, TF and EIF, are set, they will remain in the INTC register until the interrupts are serviced or cleared by a software instruction.

It is recommended that a program does not use the "CALL subroutine" within the interrupt subroutine. Interrupts often occur in an unpredictable manner or need to be serviced immediately in some applications. If only one stack is left and enabling the interrupt is not well controlled, the original control sequence will be damaged if a "CALL" is executed in the interrupt subroutine.

Oscillator Configuration

These devices provide two types of system oscillator circuits, an RC oscillator and a 32768Hz crystal oscillator, the choice of which is determined by software.

If an RC oscillator is used, an external resistor, whose resistance must range from 100kΩ to 2MΩ, should be connected between OSC1 and VSS. The RC oscillator provides the most cost effective solution, however, the frequency of oscillation may vary with VDD, temperatures and the chip itself due to process variations. It is, therefore, not suitable for timing sensitive operations where an accurate oscillator frequency is desired.

The other oscillator circuit is designed for the real time clock. For this device, only a 32768Hz crystal oscillator can be used. The crystal should be connected between OSC3 and OSC4.

The RTC oscillator circuit can be controlled to start up quickly by setting the "QOSC" bit (bit 4 of mode). It is

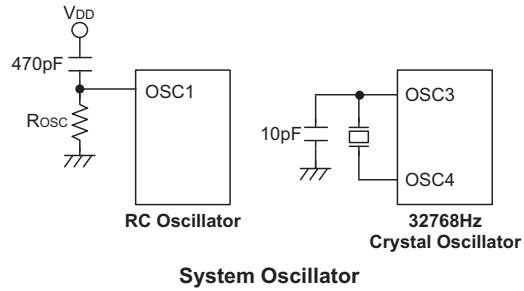

recommended to turn on the quick oscillating function at power on until the RTC oscillator is stable, and then turn it off after 2 seconds to reduce power consumption.

The WDT oscillator is a free running on-chip RC oscillator, and requires no external components. Although when the system enters the power down mode, the system clock stops, the WDT oscillator will keep running with a period of approximately 65μs at 5V. The WDT oscillator can be disabled by a configuration option to conserve power.

Watchdog Timer – WDT

The WDT clock source is implemented by a internal WDT OSC, the external 32768Hz (f_{RTC}) or the instruction clock (system clock divided by 4), the choice of which is determined by configuration option. This timer is designed to prevent software malfunctions or sequences jumping to an unknown location with unpredictable results. The Watchdog can be disabled by a configuration option. If the Watchdog Timer is disabled, all the executions related to WDT will result in no operation.

If the device operates in a noisy environment, using the on-chip WDT OSC or 32768Hz crystal oscillator is strongly recommended.

When the WDT clock source is selected, it will be first divided by 16 (4-stage), and then divided by the TMRC prescaler (8-stage), after that, divided by 512 (9-stage) to get the nominal time-out period. By using the TMRC prescaler, longer time-out periods can be realized. Writing data to PSC2, PSC1, PSC0 can give different time-out periods. The WDT OSC period is 65μs. This time-out period may vary with temperature, VDD and process variations. The WDT OSC keep running in any operation mode.

If the instruction clock (system clock/4) is selected as the WDT clock source, the WDT operates in the same manner.

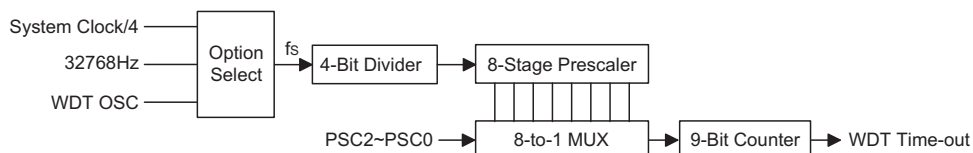

Watchdog Timer

If the WDT clock source is the 32768Hz, the WDT also operates in the same manner.

The WDT time-out under normal mode or slow mode will initialize a "chip reset" and set the status bit "TO". But in the idle mode, that is after a HALT instruction is executed, the time-out will initialize a "warm reset" and only the program counter and stack pointer are reset to 0.

To clear the WDT contents (not including the 4-bit divider and the 8-stage prescaler), three methods are adopted; an external reset (a low level to RES pin), software instruction and a "HALT" instruction.

The software instruction includes a "CLR WDT" instruction, and the instruction pair "CLR WDT1" and "CLR WDT2". Of these two types of instruction, only one can

be active depending on the configuration option "WDT" instruction. If the "CLR WDT" is selected (i.e. One clear instruction), any execution of the CLR WDT instruction will clear the WDT. In the case that "CLR WDT1" and "CLR WDT2" are chosen (i.e. two clear instructions), these two instructions must be executed to clear the WDT; otherwise, the WDT may reset the chip as a result of a time-out.

Operation Mode

The device support two system clocks and three operation modes. The system clock can be either an RC oscillator or a 32768Hz RTC. The three operational modes are, Normal, Slow, or Idle mode. These are all selected by software.

Bit No.	Label	Function
0	MODS	System clock high/low mode select bit 0= RC system clock select 1= 32768Hz system clock select and RC system clock stop Note that if the 32768Hz system clock is selected, then the WDT clock source configuration option must also select the 32768Hz oscillator as its clock source, otherwise unpredictable system operation may occur.
1, 2, 3	—	Unused bit, read as "0"
4	QOSC	32768Hz OSC quick start-up 0=quick start; 1=slow start
5, 6, 7	—	Unused bit, read as "0"

MODE (20H) Register

Mode	System Clock	HALT Instruction	MODS	RC Oscillator	32768Hz
Normal	RC oscillator	No Executed	0	On	On
Slow	32768Hz	No Executed	1	Off	On
Idle	HALT	Be executed	x	Off	On

Operation Mode

Power Down Operation – HALT

The HALT mode is entered using the "HALT" instruction and results in the following:

- The system oscillator will be turned off but the WDT remains operational if its clock source is the internal WDT oscillator.
- The contents of the on chip RAM and registers remain unchanged.
- The WDT will be cleared. The WDT will resume counting, if the WDT clock source is the internal WDT oscillator.
- All of the I/O ports will maintain their original status.
- The PDF flag will be set and the TO flag will be cleared.

The system can leave the HALT mode by means of an external reset, an interrupt, an external falling edge signal on port A or a WDT overflow. An external reset causes a device initialization and the WDT overflow per-

forms a "warm reset". After the TO and PDF flags are examined, the reason behind the reset can be determined. The PDF flag is cleared by a system power-up or executing the "CLR WDT" instruction and is set when executing the "HALT" instruction. The TO flag is set if the WDT time-out occurs, and causes a wake-up that only resets the program counter and stack pointer, the other circuits remain in their original status.

The port A wake-up and interrupt methods can be considered as a continuation of normal execution. Each port A pin can be independently selected to wake up the device via configuration options. If awakened by an I/O port stimulus, the program will resume execution at the next instruction. If awakened by an interrupt, two sequences may occur. If the related interrupt is disabled or the interrupt is enabled but the stack is full, the program will resume execution at the next instruction. If the interrupt is enabled and the stack is not full, the regular inter-

rupt response takes place. If an interrupt request flag is set to "1" before entering the HALT mode, the wake-up function of the related interrupt will be disabled. Once a wake-up event occurs, it takes 1024 system clock periods to resume normal operation. In other words, a dummy period will be inserted after a wake-up. If the wake-up results from an interrupt acknowledge signal, the actual interrupt subroutine execution will be delayed by one or more cycles. If the wake-up results in the next instruction execution, this will be executed immediately after the dummy period is finished.

To minimize power consumption, all the I/O pins should be carefully managed before entering the HALT status. The RTC oscillator will keep running when the device is in the HALT mode, if the RTC oscillator is enabled.

Reset

There are three ways in which a reset can occur:

- $\overline{\text{RES}}$ reset during normal operation
- $\overline{\text{RES}}$ reset during HALT
- WDT time-out reset during normal operation

A the time-out during a HALT is different from the other chip reset conditions, since it can perform a "warm reset" that resets only the program counter and SP, leaving the other circuits in their original state. Some registers remain unchanged during other reset conditions. Most registers are reset to their "initial condition" when the reset conditions are met. By examining the PDF and TO flags, the program can distinguish between different "chip resets".

TO	PDF	RESET Conditions
0	0	$\overline{\text{RES}}$ reset during power-up
u	u	$\overline{\text{RES}}$ reset during normal operation
0	1	$\overline{\text{RES}}$ wake-up HALT
1	u	WDT time-out during normal operation
1	1	WDT wake-up HALT

Note: "u" stands for "unchanged"

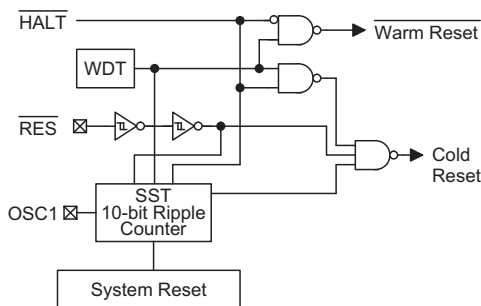

Reset Configuration

To guarantee that the system oscillator is running and stable, the SST (System Start-up Timer) provides an extra delay of 1024 system clock pulses when the system reset (power-up, WDT time-out or $\overline{\text{RES}}$ reset) or when the system awakes from the HALT state.

When a system reset occurs, the SST delay is added during the reset period. Any wake-up from HALT will enable the SST delay.

An extra option load time delay is added during a system reset (power-up, WDT time-out at normal mode or $\overline{\text{RES}}$ reset).

The functional unit chip reset status are shown below.

Program Counter	000H
Interrupt	Disable
Prescaler	Clear
WDT	Clear. After master reset, WDT begins counting
Timer/Event Counter	Off
Input/Output Ports	Input mode
Stack Pointer	Points to the top of the stack

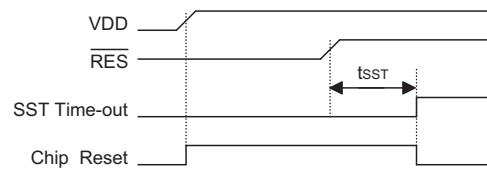

Reset Timing Chart

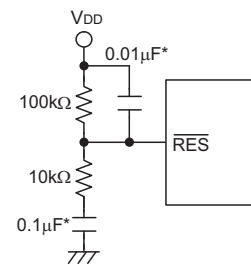

Reset Circuit

Note: "*" Make the length of the wiring, which is connected to the RES pin as short as possible, to avoid noise interference.

The states of the registers are summarised in the table.

Register	Reset (Power On)	WDT Time-out (Normal Operation)	RES Reset (Normal Operation)	RES Reset (HALT)	WDT Time-out (HALT)*
MP0	-xxx xxxx	-uuu uuuu	-uuu uuuu	-uuu uuuu	-uuu uuuu
MP1	-xxx xxxx	-uuu uuuu	-uuu uuuu	-uuu uuuu	-uuu uuuu
ACC	xxxx xxxx	uuuu uuuu	uuuu uuuu	uuuu uuuu	uuuu uuuu
PCL	0000 0000	0000 0000	0000 0000	0000 0000	0000 0000
TBLP	xxxx xxxx	uuuu uuuu	uuuu uuuu	uuuu uuuu	uuuu uuuu
TBLH	--xx xxxx	--uu uuuu	--uu uuuu	--uu uuuu	--uu uuuu
STATUS	--00 xxxx	--1u uuuu	--uu uuuu	--01 uuuu	--11 uuuu
INTC	--00 -000	--00 -000	--00 -000	--00 -000	--uu -uuu
TMR	xxxx xxxx	xxxx xxxx	xxxx xxxx	xxxx xxxx	uuuu uuuu
TMRC	00-0 1000	00-0 1000	00-0 1000	00-0 1000	uu-u uuuu
PA	1111 1111	1111 1111	1111 1111	1111 1111	uuuu uuuu
PAC	1111 1111	1111 1111	1111 1111	1111 1111	uuuu uuuu
PB	1111 1111	1111 1111	1111 1111	1111 1111	uuuu uuuu
PBC	1111 1111	1111 1111	1111 1111	1111 1111	uuuu uuuu
PC	0000 0000	0000 0000	0000 0000	0000 0000	uuuu uuuu
PD	1111 1111	1111 1111	1111 1111	1111 1111	uuuu uuuu
PE	1111 1111	1111 1111	1111 1111	1111 1111	uuuu uuuu
MODE	---0 ---0	---0 ---0	---0 ---0	---0 ---0	---u ---u

Note: "*" stands for "warm reset"
 "u" stands for "unchanged"
 "x" stands for "unknown"

Timer/Event Counter

A single Timer/event counter is implemented in the microcontroller. The timer/event counter contains an 8-bit programmable count-up counter whose clock may be sourced from an external source or from the system clock/4 or f_{SP} .

The f_{SP} clock source is implemented by the WDT OSC, an external 32768Hz (f_{RTC}) or an instruction clock (system clock divided by 4), determined by configuration option. If one of these three source is selected, it will be first divided by 16 (4-stage), and then divided by the TMRC prescaler (8-stage) to get an f_{SP} output period. By using the TMRC prescaler, longer time-out periods can be realized. Writing data to PSC2, PSC1, PSC0 can give different f_{SP} output periods.

Using internal clock sources, there are 2 reference time-bases for the timer/event counter. The internal clock source can be sourced from $f_{SYS}/4$ or f_{SP} via a configuration options. Using an external clock input allows the user to count external events, measure time intervals or pulse widths, or generate an accurate time base, while using the internal clock allows the user to generate an accurate time base.

There are two registers related to the timer/event counter; TMR ([0DH]) and TMRC ([0EH]). Two physical registers are mapped to the TMR register location. Writing to TMR places the start value in the timer/event counter preload register while reading the TMR register retrieves the contents of the timer/event counter. The TMRC register is a timer/event counter control register which defines some options.

The TM0, TM1 bits define the operating mode. The event count mode is used to count external events, which means the clock source must come from the external timer pin, TMR. The timer mode functions as a normal timer with the clock source coming from the f_{INT} clock. The pulse width measurement mode can be used to count the duration of a high or low-level signal on the external timer pin, TMR. The counting is based on the f_{INT} clock.

In the event count or timer mode, once the timer/event counter is enabled, it begins counting from the value placed in the timer/event counter. From this initial value it will count up to a value of FFH. Once an overflow occurs, the counter is reloaded from the timer/event counter preload register and at the same time generates the interrupt request flag, TF; bit 5 of the INTC.

In the pulse width measurement mode with the TON and TE bits equal to one, once it goes from low to high (or high to low if the TE bits is "0") it will start counting until the TMR returns to the original level and resets the TON. The measured result will remain in the timer/event counter even if the activated transient occurs again. In other words, only one cycle measurement can be done. Until setting the TON, the cycle measurement will function again as long as it receives further transient pulse. Note that, in this operating mode, the timer/event counter starts counting not according to the logic level but according to the transient edges. In the case of counter overflows, the counter is reloaded from the timer/event counter preload register and issues the interrupt request just like the other two modes. To enable the counting operation, the timer ON bit (TON; bit 4 of the TMRC) should be set to 1. In the pulse width measurement

mode, the TON will be cleared automatically after the measurement cycle is completed. But in the other two modes the TON can only be reset by instructions. The overflow of the timer/event counter is one of the wake-up sources. No matter what the operation mode is, writing a 0 to ETI can disable the corresponding interrupt services.

In the case of timer/event counter OFF condition, writing data to the timer/event counter preload register will also reload that data to the timer/event counter. But if the timer/event counter is turned on, data written to it will only be kept in the timer/event counter preload register. The timer/event counter will still operate until overflow occurs (a timer/event counter reloading will occur at the same time). When the timer/event counter (reading TMR) is read, the clock will be blocked to avoid errors.

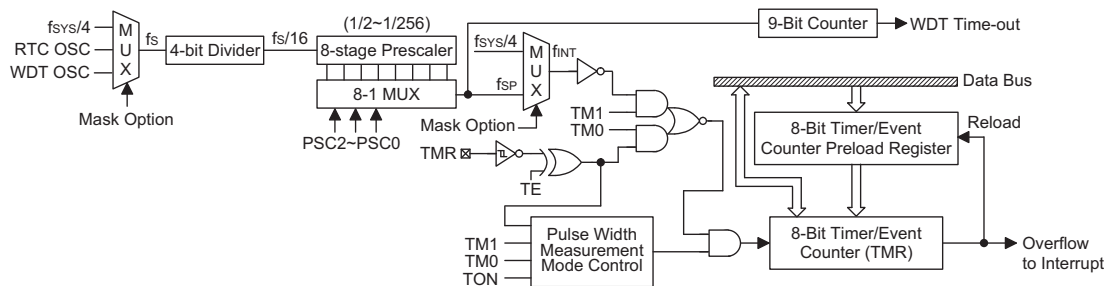

Timer/Event Counter and WDT

Bit No.	Label	Function
0 1 2	PSC0 PSC1 PSC2	Define the prescaler stages, PSC2, PSC1, PSC0= 000: $f_{SP}=f_S/32$ 001: $f_{SP}=f_S/64$ 010: $f_{SP}=f_S/128$ 011: $f_{SP}=f_S/256$ 100: $f_{SP}=f_S/512$ 101: $f_{SP}=f_S/1024$ 110: $f_{SP}=f_S/2048$ 111: $f_{SP}=f_S/4096$
3	TE	Defines the TMR active edge of the timer/event counter: In Event Counter Mode (TM1, TM0)=(0,1): 1: count on falling edge; 0: count on rising edge In Pulse Width measurement mode (TM1, TM0)=(1,1): 1: start counting on the rising edge, stop on the falling edge; 0: start counting on the falling edge, stop on the rising edge
4	TON	To enable or disable timer 0 counting (0=disable; 1=enable)
5	—	Unused bit, read as "0"
6 7	TM0 TM1	Define the operating mode, TM1, TM0= 01=Event count mode (external clock) 10=Timer mode (internal clock) 11=Pulse width measurement mode 00=Unused

TMRC (0EH) Register

As clock blocking may result in a counting error, this must be taken into consideration by the programmer. The bit2~bit0 of the TMRC can be used to define the pre-scaling stages of the internal clock sources of the timer/event counter. The definitions are as shown.

Input/Output Ports

There are 16 bidirectional input/output (PA, PB) lines and 8 PMOS (PC), 16 NMOS (PD, PE) output lines in the microcontroller, labeled from PA to PE, which are mapped to the data memory of [12H], [14H], [16H], [18H] and [1AH] respectively. All pins on PA~PB can be used for both input and output operations.

For the input operation, these ports are non-latching, that is, the inputs must be ready at the T2 rising edge of instruction "MOV A,[m]" (m=12H, 14H). For output operation, all the data is latched and remains unchanged until the output latch is rewritten.

The PA and PB have their own control registers (PAC, PBC) to control the input/output configuration. These two control registers are mapped to locations 13H and 15H. CMOS/PMOS output or Schmitt trigger input with structures can be reconfigured dynamically under software control. The control registers specifies which pin are set as input and which are set as outputs. To setup a pin as an input the corresponding bit of the control register must be set high, for an output it must be set low.

The PC can be used for output operation only. Resetting its output register to low will effectively places its PMOS output transistor in high impedance state. Setting output

register to high will force PC to output high state.

The external interrupt pin INT is pin-share with output pin PD0.

The PD and PE can be used for output operation only. Setting its output register high which effectively places its NMOS output transistor in high impedance state. Re-setting output register to low will force to output low state.

After a chip reset, these input/output lines remain at high levels or floating state (depending on the pull-high options). Each bit of these input/output latches can be set or cleared by "SET [m].i" and "CLR [m].i" (m=12H, 14H, 16H, 18H or 1AH) instructions.

Some instructions first input data and then follow the output operations. For example, "SET [m].i", "LR [m].i", "CPL [m]", "CPLA [m]" read the entire port states into the CPU, execute the defined operations (bit-operation), and then write the results back to the latches or the accumulator.

Each line of port A has the capability of waking-up the device.

There is a pull-high option available for PA0~PA7 lines (port option). Once the pull-high option of an I/O line is selected, the I/O line have pull-high resistor. Otherwise, the pull-high resistor is absent. It should be noted that a non-pull-high I/O line operating in input mode will cause a floating state.

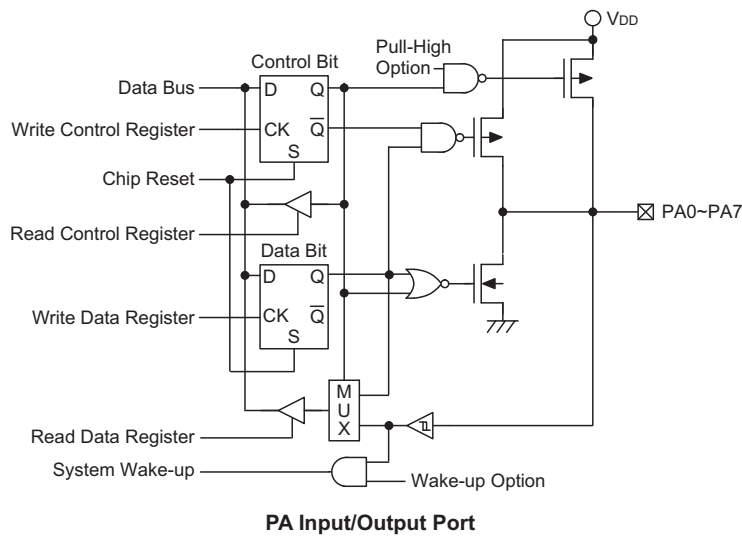

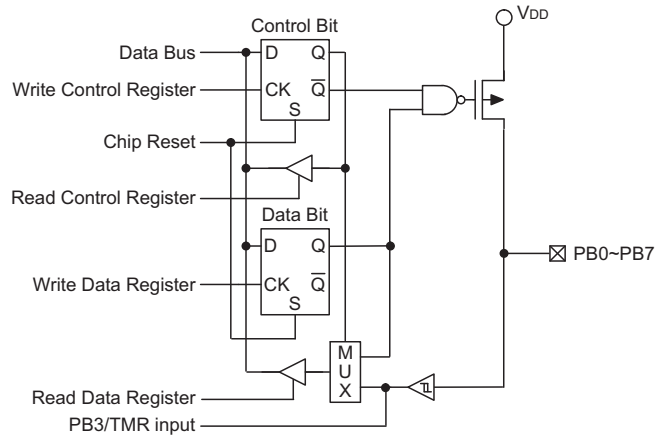

PB Input/Output Port

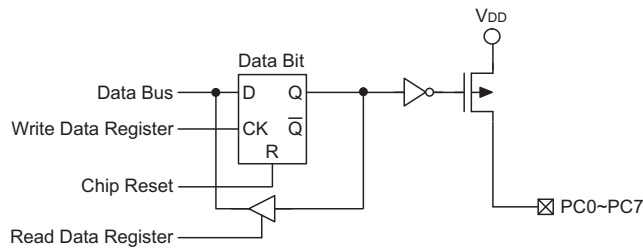

PC Output Port

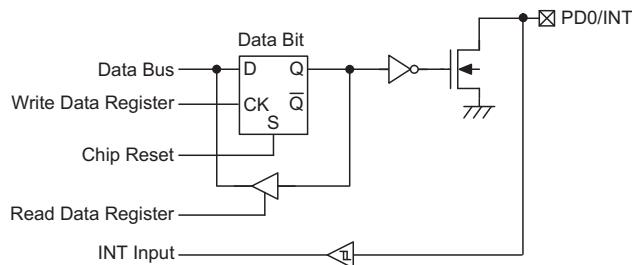

PD0 Input/Output Port

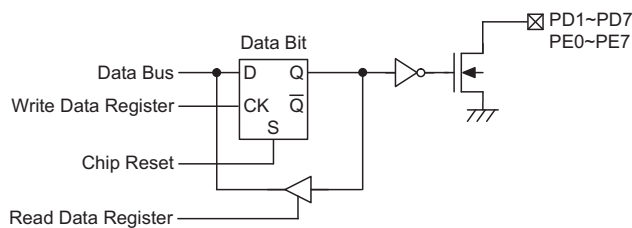

PD1~PD7, PE Output Ports

Low Voltage Reset – LVR

The microcontroller provides a low voltage reset circuit in order to monitor the supply voltage of the device. If the supply voltage of the device is within the range $0.9V \sim V_{LVR}$, such as changing a battery, the LVR will automatically reset the device internally.

The LVR includes the following specifications:

- The low voltage ($0.9V \sim V_{LVR}$) has to remain in their original state for more than 1ms. If the low voltage state does not exceed 1ms, the LVR will ignore it and do not perform a reset function.
- The LVR uses the "OR" function with the external \overline{RES} signal to perform a chip reset.

The relationship between V_{DD} and V_{LVR} is shown below.

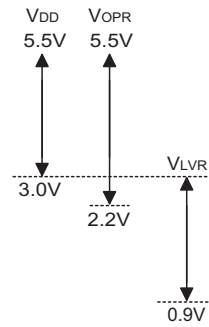

Note: V_{OPR} is the voltage range for proper chip operation at 4MHz system clock.

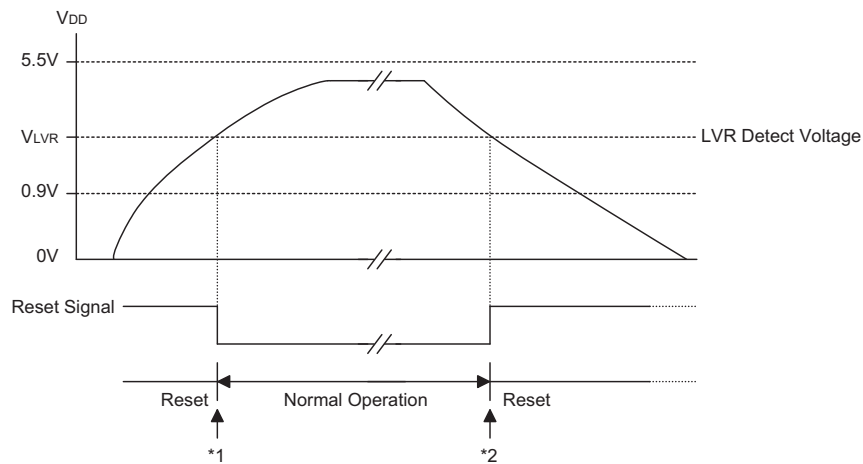

Low Voltage Reset

Note: *1: To make sure that the system oscillator has stabilized, the SST provides an extra delay of 1024 system clock pulses before entering the normal operation.

*2: Since a low voltage has to be maintained for more than 1ms, therefore a 1ms delay is provided before entering the reset mode.

Options

The following table shows all kinds of options in the microcontroller. All of the options must be defined to ensure having a proper functioning system.

Items	Options
1	PA0~PA7 bit wake-up enable or disable (by bit)
2	PA pull-high enable or disable (by port)
3	WDT clock source: WDT oscillator or $f_{SYS}/4$ or 32768Hz oscillator
4	WDT enable or disable
5	CLRWDT instructions: 1 or 2 instructions
6	Timer/event counter clock sources: $f_{SYS}/4$ or f_{SP}
7	LVR enable or disable

Application Circuits

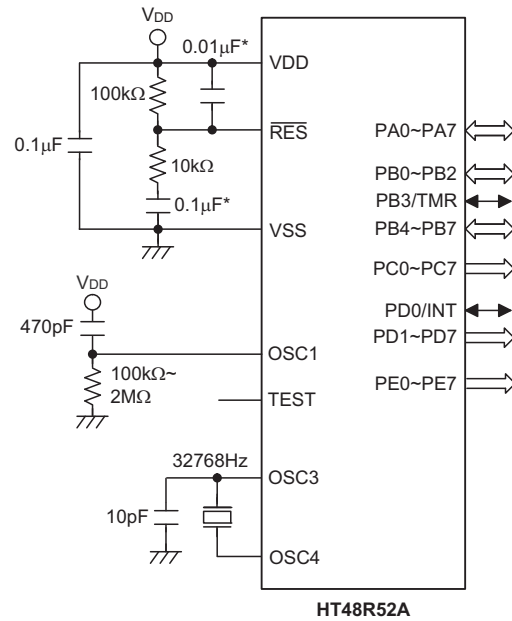

Note: The resistance and capacitance for the reset circuit should be chosen in such a way as to ensure that VDD is stable and remains within a valid operating voltage range before bringing $\overline{\text{RES}}$ high.

*** Make the length of the wiring, which is connected to the $\overline{\text{RES}}$ pin as short as possible, to avoid noise interference.

Instruction Set

Introduction

Central to the successful operation of any microcontroller is its instruction set, which is a set of program instruction codes that directs the microcontroller to perform certain operations. In the case of Holtek microcontrollers, a comprehensive and flexible set of over 60 instructions is provided to enable programmers to implement their application with the minimum of programming overheads.

For easier understanding of the various instruction codes, they have been subdivided into several functional groupings.

Instruction Timing

Most instructions are implemented within one instruction cycle. The exceptions to this are branch, call, or table read instructions where two instruction cycles are required. One instruction cycle is equal to 4 system clock cycles, therefore in the case of an 8MHz system oscillator, most instructions would be implemented within 0.5 μ s and branch or call instructions would be implemented within 1 μ s. Although instructions which require one more cycle to implement are generally limited to the JMP, CALL, RET, RETI and table read instructions, it is important to realize that any other instructions which involve manipulation of the Program Counter Low register or PCL will also take one more cycle to implement. As instructions which change the contents of the PCL will imply a direct jump to that new address, one more cycle will be required. Examples of such instructions would be "CLR PCL" or "MOV PCL, A". For the case of skip instructions, it must be noted that if the result of the comparison involves a skip operation then this will also take one more cycle, if no skip is involved then only one cycle is required.

Moving and Transferring Data

The transfer of data within the microcontroller program is one of the most frequently used operations. Making use of three kinds of MOV instructions, data can be transferred from registers to the Accumulator and vice-versa as well as being able to move specific immediate data directly into the Accumulator. One of the most important data transfer applications is to receive data from the input ports and transfer data to the output ports.

Arithmetic Operations

The ability to perform certain arithmetic operations and data manipulation is a necessary feature of most microcontroller applications. Within the Holtek microcontroller instruction set are a range of add and subtract instruction mnemonics to enable the necessary arithmetic to be carried out. Care must be taken to en-

sure correct handling of carry and borrow data when results exceed 255 for addition and less than 0 for subtraction. The increment and decrement instructions INC, INCA, DEC and DECA provide a simple means of increasing or decreasing by a value of one of the values in the destination specified.

Logical and Rotate Operations

The standard logical operations such as AND, OR, XOR and CPL all have their own instruction within the Holtek microcontroller instruction set. As with the case of most instructions involving data manipulation, data must pass through the Accumulator which may involve additional programming steps. In all logical data operations, the zero flag may be set if the result of the operation is zero. Another form of logical data manipulation comes from the rotate instructions such as RR, RL, RRC and RLC which provide a simple means of rotating one bit right or left. Different rotate instructions exist depending on program requirements. Rotate instructions are useful for serial port programming applications where data can be rotated from an internal register into the Carry bit from where it can be examined and the necessary serial bit set high or low. Another application where rotate data operations are used is to implement multiplication and division calculations.

Branches and Control Transfer

Program branching takes the form of either jumps to specified locations using the JMP instruction or to a subroutine using the CALL instruction. They differ in the sense that in the case of a subroutine call, the program must return to the instruction immediately when the subroutine has been carried out. This is done by placing a return instruction RET in the subroutine which will cause the program to jump back to the address right after the CALL instruction. In the case of a JMP instruction, the program simply jumps to the desired location. There is no requirement to jump back to the original jumping off point as in the case of the CALL instruction. One special and extremely useful set of branch instructions are the conditional branches. Here a decision is first made regarding the condition of a certain data memory or individual bits. Depending upon the conditions, the program will continue with the next instruction or skip over it and jump to the following instruction. These instructions are the key to decision making and branching within the program perhaps determined by the condition of certain input switches or by the condition of internal data bits.

Bit Operations

The ability to provide single bit operations on Data Memory is an extremely flexible feature of all Holtek microcontrollers. This feature is especially useful for output port bit programming where individual bits or port pins can be directly set high or low using either the "SET [m].i" or "CLR [m].i" instructions respectively. The feature removes the need for programmers to first read the 8-bit output port, manipulate the input data to ensure that other bits are not changed and then output the port with the correct new data. This read-modify-write process is taken care of automatically when these bit operation instructions are used.

Table Read Operations

Data storage is normally implemented by using registers. However, when working with large amounts of fixed data, the volume involved often makes it inconvenient to store the fixed data in the Data Memory. To overcome this problem, Holtek microcontrollers allow an area of Program Memory to be setup as a table where data can be directly stored. A set of easy to use instructions provides the means by which this fixed data can be referenced and retrieved from the Program Memory.

Other Operations

In addition to the above functional instructions, a range of other instructions also exist such as the "HALT" instruction for Power-down operations and instructions to control the operation of the Watchdog Timer for reliable program operations under extreme electric or electromagnetic environments. For their relevant operations, refer to the functional related sections.

Instruction Set Summary

The following table depicts a summary of the instruction set categorised according to function and can be consulted as a basic instruction reference using the following listed conventions.

Table conventions:

x: Bits immediate data

m: Data Memory address

A: Accumulator

i: 0-7 number of bits

addr: Program memory address

Mnemonic	Description	Cycles	Flag Affected
Arithmetic			
ADD A,[m]	Add Data Memory to ACC	1	Z, C, AC, OV
ADDM A,[m]	Add ACC to Data Memory	↑Note	Z, C, AC, OV
ADD A,x	Add immediate data to ACC	1	Z, C, AC, OV
ADC A,[m]	Add Data Memory to ACC with Carry	1	Z, C, AC, OV
ADCM A,[m]	Add ACC to Data memory with Carry	↑Note	Z, C, AC, OV
SUB A,x	Subtract immediate data from the ACC	1	Z, C, AC, OV
SUB A,[m]	Subtract Data Memory from ACC	1	Z, C, AC, OV
SUBM A,[m]	Subtract Data Memory from ACC with result in Data Memory	↑Note	Z, C, AC, OV
SBC A,[m]	Subtract Data Memory from ACC with Carry	1	Z, C, AC, OV
SBCM A,[m]	Subtract Data Memory from ACC with Carry, result in Data Memory	↑Note	Z, C, AC, OV
DAA [m]	Decimal adjust ACC for Addition with result in Data Memory	↑Note	C
Logic Operation			
AND A,[m]	Logical AND Data Memory to ACC	1	Z
OR A,[m]	Logical OR Data Memory to ACC	1	Z
XOR A,[m]	Logical XOR Data Memory to ACC	1	Z
ANDM A,[m]	Logical AND ACC to Data Memory	↑Note	Z
ORM A,[m]	Logical OR ACC to Data Memory	↑Note	Z
XORM A,[m]	Logical XOR ACC to Data Memory	↑Note	Z
AND A,x	Logical AND immediate Data to ACC	1	Z
OR A,x	Logical OR immediate Data to ACC	1	Z
XOR A,x	Logical XOR immediate Data to ACC	1	Z
CPL [m]	Complement Data Memory	↑Note	Z
CPLA [m]	Complement Data Memory with result in ACC	1	Z
Increment & Decrement			
INCA [m]	Increment Data Memory with result in ACC	1	Z
INC [m]	Increment Data Memory	↑Note	Z
DECA [m]	Decrement Data Memory with result in ACC	1	Z
DEC [m]	Decrement Data Memory	↑Note	Z

Mnemonic	Description	Cycles	Flag Affected
Rotate			
RRA [m]	Rotate Data Memory right with result in ACC	1	None
RR [m]	Rotate Data Memory right	↑ ^{Note}	None
RRCA [m]	Rotate Data Memory right through Carry with result in ACC	1	C
RRC [m]	Rotate Data Memory right through Carry	↑ ^{Note}	C
RLA [m]	Rotate Data Memory left with result in ACC	1	None
RL [m]	Rotate Data Memory left	↑ ^{Note}	None
RLCA [m]	Rotate Data Memory left through Carry with result in ACC	1	C
RLC [m]	Rotate Data Memory left through Carry	↑ ^{Note}	C
Data Move			
MOV A,[m]	Move Data Memory to ACC	1	None
MOV [m],A	Move ACC to Data Memory	↑ ^{Note}	None
MOV A,x	Move immediate data to ACC	1	None
Bit Operation			
CLR [m].i	Clear bit of Data Memory	↑ ^{Note}	None
SET [m].i	Set bit of Data Memory	↑ ^{Note}	None
Branch			
JMP addr	Jump unconditionally	2	None
SZ [m]	Skip if Data Memory is zero	↑ ^{Note}	None
SZA [m]	Skip if Data Memory is zero with data movement to ACC	↑ ^{note}	None
SZ [m].i	Skip if bit i of Data Memory is zero	↑ ^{Note}	None
SNZ [m].i	Skip if bit i of Data Memory is not zero	↑ ^{Note}	None
SIZ [m]	Skip if increment Data Memory is zero	↑ ^{Note}	None
SDZ [m]	Skip if decrement Data Memory is zero	↑ ^{Note}	None
SIZA [m]	Skip if increment Data Memory is zero with result in ACC	↑ ^{Note}	None
SDZA [m]	Skip if decrement Data Memory is zero with result in ACC	↑ ^{Note}	None
CALL addr	Subroutine call	2	None
RET	Return from subroutine	2	None
RET A,x	Return from subroutine and load immediate data to ACC	2	None
RETI	Return from interrupt	2	None
Table Read			
TABRDC [m]	Read table (current page) to TBLH and Data Memory	2 ^{Note}	None
TABRDL [m]	Read table (last page) to TBLH and Data Memory	2 ^{Note}	None
Miscellaneous			
NOP	No operation	1	None
CLR [m]	Clear Data Memory	↑ ^{Note}	None
SET [m]	Set Data Memory	↑ ^{Note}	None
CLR WDT	Clear Watchdog Timer	1	TO, PDF
CLR WDT1	Pre-clear Watchdog Timer	1	TO, PDF
CLR WDT2	Pre-clear Watchdog Timer	1	TO, PDF
SWAP [m]	Swap nibbles of Data Memory	↑ ^{Note}	None
SWAPA [m]	Swap nibbles of Data Memory with result in ACC	1	None
HALT	Enter power down mode	1	TO, PDF

- Note:
1. For skip instructions, if the result of the comparison involves a skip then two cycles are required, if no skip takes place only one cycle is required.
 2. Any instruction which changes the contents of the PCL will also require 2 cycles for execution.
 3. For the "CLR WDT1" and "CLR WDT2" instructions the TO and PDF flags may be affected by the execution status. The TO and PDF flags are cleared after both "CLR WDT1" and "CLR WDT2" instructions are consecutively executed. Otherwise the TO and PDF flags remain unchanged.

Instruction Definition

ADC A,[m]	Add Data Memory to ACC with Carry
Description	The contents of the specified Data Memory, Accumulator and the carry flag are added. The result is stored in the Accumulator.
Operation	$ACC \leftarrow ACC + [m] + C$
Affected flag(s)	OV, Z, AC, C
ADCM A,[m]	Add ACC to Data Memory with Carry
Description	The contents of the specified Data Memory, Accumulator and the carry flag are added. The result is stored in the specified Data Memory.
Operation	$[m] \leftarrow ACC + [m] + C$
Affected flag(s)	OV, Z, AC, C
ADD A,[m]	Add Data Memory to ACC
Description	The contents of the specified Data Memory and the Accumulator are added. The result is stored in the Accumulator.
Operation	$ACC \leftarrow ACC + [m]$
Affected flag(s)	OV, Z, AC, C
ADD A,x	Add immediate data to ACC
Description	The contents of the Accumulator and the specified immediate data are added. The result is stored in the Accumulator.
Operation	$ACC \leftarrow ACC + x$
Affected flag(s)	OV, Z, AC, C
ADDM A,[m]	Add ACC to Data Memory
Description	The contents of the specified Data Memory and the Accumulator are added. The result is stored in the specified Data Memory.
Operation	$[m] \leftarrow ACC + [m]$
Affected flag(s)	OV, Z, AC, C
AND A,[m]	Logical AND Data Memory to ACC
Description	Data in the Accumulator and the specified Data Memory perform a bitwise logical AND operation. The result is stored in the Accumulator.
Operation	$ACC \leftarrow ACC \text{ "AND" } [m]$
Affected flag(s)	Z
AND A,x	Logical AND immediate data to ACC
Description	Data in the Accumulator and the specified immediate data perform a bitwise logical AND operation. The result is stored in the Accumulator.
Operation	$ACC \leftarrow ACC \text{ "AND" } x$
Affected flag(s)	Z
ANDM A,[m]	Logical AND ACC to Data Memory
Description	Data in the specified Data Memory and the Accumulator perform a bitwise logical AND operation. The result is stored in the Data Memory.
Operation	$[m] \leftarrow ACC \text{ "AND" } [m]$
Affected flag(s)	Z

CALL addr	Subroutine call
Description	Unconditionally calls a subroutine at the specified address. The Program Counter then increments by 1 to obtain the address of the next instruction which is then pushed onto the stack. The specified address is then loaded and the program continues execution from this new address. As this instruction requires an additional operation, it is a two cycle instruction.
Operation	Stack \leftarrow Program Counter + 1 Program Counter \leftarrow addr
Affected flag(s)	None
CLR [m]	Clear Data Memory
Description	Each bit of the specified Data Memory is cleared to 0.
Operation	[m] \leftarrow 00H
Affected flag(s)	None
CLR [m].i	Clear bit of Data Memory
Description	Bit i of the specified Data Memory is cleared to 0.
Operation	[m].i \leftarrow 0
Affected flag(s)	None
CLR WDT	Clear Watchdog Timer
Description	The TO, PDF flags and the WDT are all cleared.
Operation	WDT cleared TO \leftarrow 0 PDF \leftarrow 0
Affected flag(s)	TO, PDF
CLR WDT1	Pre-clear Watchdog Timer
Description	The TO, PDF flags and the WDT are all cleared. Note that this instruction works in conjunction with CLR WDT2 and must be executed alternately with CLR WDT2 to have effect. Repeatedly executing this instruction without alternately executing CLR WDT2 will have no effect.
Operation	WDT cleared TO \leftarrow 0 PDF \leftarrow 0
Affected flag(s)	TO, PDF
CLR WDT2	Pre-clear Watchdog Timer
Description	The TO, PDF flags and the WDT are all cleared. Note that this instruction works in conjunction with CLR WDT1 and must be executed alternately with CLR WDT1 to have effect. Repeatedly executing this instruction without alternately executing CLR WDT1 will have no effect.
Operation	WDT cleared TO \leftarrow 0 PDF \leftarrow 0
Affected flag(s)	TO, PDF

CPL [m]	Complement Data Memory
Description	Each bit of the specified Data Memory is logically complemented (1's complement). Bits which previously contained a 1 are changed to 0 and vice versa.
Operation	$[m] \leftarrow \overline{[m]}$
Affected flag(s)	Z
CPLA [m]	Complement Data Memory with result in ACC
Description	Each bit of the specified Data Memory is logically complemented (1's complement). Bits which previously contained a 1 are changed to 0 and vice versa. The complemented result is stored in the Accumulator and the contents of the Data Memory remain unchanged.
Operation	$ACC \leftarrow \overline{[m]}$
Affected flag(s)	Z
DAA [m]	Decimal-Adjust ACC for addition with result in Data Memory
Description	Convert the contents of the Accumulator value to a BCD (Binary Coded Decimal) value resulting from the previous addition of two BCD variables. If the low nibble is greater than 9 or if AC flag is set, then a value of 6 will be added to the low nibble. Otherwise the low nibble remains unchanged. If the high nibble is greater than 9 or if the C flag is set, then a value of 6 will be added to the high nibble. Essentially, the decimal conversion is performed by adding 00H, 06H, 60H or 66H depending on the Accumulator and flag conditions. Only the C flag may be affected by this instruction which indicates that if the original BCD sum is greater than 100, it allows multiple precision decimal addition.
Operation	$[m] \leftarrow ACC + 00H$ or $[m] \leftarrow ACC + 06H$ or $[m] \leftarrow ACC + 60H$ or $[m] \leftarrow ACC + 66H$
Affected flag(s)	C
DEC [m]	Decrement Data Memory
Description	Data in the specified Data Memory is decremented by 1.
Operation	$[m] \leftarrow [m] - 1$
Affected flag(s)	Z
DECA [m]	Decrement Data Memory with result in ACC
Description	Data in the specified Data Memory is decremented by 1. The result is stored in the Accumulator. The contents of the Data Memory remain unchanged.
Operation	$ACC \leftarrow [m] - 1$
Affected flag(s)	Z
HALT	Enter power down mode
Description	This instruction stops the program execution and turns off the system clock. The contents of the Data Memory and registers are retained. The WDT and prescaler are cleared. The power down flag PDF is set and the WDT time-out flag TO is cleared.
Operation	TO \leftarrow 0 PDF \leftarrow 1
Affected flag(s)	TO, PDF

INC [m]	Increment Data Memory
Description	Data in the specified Data Memory is incremented by 1.
Operation	$[m] \leftarrow [m] + 1$
Affected flag(s)	Z
INCA [m]	Increment Data Memory with result in ACC
Description	Data in the specified Data Memory is incremented by 1. The result is stored in the Accumulator. The contents of the Data Memory remain unchanged.
Operation	$ACC \leftarrow [m] + 1$
Affected flag(s)	Z
JMP addr	Jump unconditionally
Description	The contents of the Program Counter are replaced with the specified address. Program execution then continues from this new address. As this requires the insertion of a dummy instruction while the new address is loaded, it is a two cycle instruction.
Operation	$Program\ Counter \leftarrow addr$
Affected flag(s)	None
MOV A,[m]	Move Data Memory to ACC
Description	The contents of the specified Data Memory are copied to the Accumulator.
Operation	$ACC \leftarrow [m]$
Affected flag(s)	None
MOV A,x	Move immediate data to ACC
Description	The immediate data specified is loaded into the Accumulator.
Operation	$ACC \leftarrow x$
Affected flag(s)	None
MOV [m],A	Move ACC to Data Memory
Description	The contents of the Accumulator are copied to the specified Data Memory.
Operation	$[m] \leftarrow ACC$
Affected flag(s)	None
NOP	No operation
Description	No operation is performed. Execution continues with the next instruction.
Operation	No operation
Affected flag(s)	None
OR A,[m]	Logical OR Data Memory to ACC
Description	Data in the Accumulator and the specified Data Memory perform a bitwise logical OR operation. The result is stored in the Accumulator.
Operation	$ACC \leftarrow ACC \text{ "OR" } [m]$
Affected flag(s)	Z

OR A,x	Logical OR immediate data to ACC
Description	Data in the Accumulator and the specified immediate data perform a bitwise logical OR operation. The result is stored in the Accumulator.
Operation	$ACC \leftarrow ACC \text{ "OR" } x$
Affected flag(s)	Z
ORM A,[m]	Logical OR ACC to Data Memory
Description	Data in the specified Data Memory and the Accumulator perform a bitwise logical OR operation. The result is stored in the Data Memory.
Operation	$[m] \leftarrow ACC \text{ "OR" } [m]$
Affected flag(s)	Z
RET	Return from subroutine
Description	The Program Counter is restored from the stack. Program execution continues at the restored address.
Operation	Program Counter \leftarrow Stack
Affected flag(s)	None
RET A,x	Return from subroutine and load immediate data to ACC
Description	The Program Counter is restored from the stack and the Accumulator loaded with the specified immediate data. Program execution continues at the restored address.
Operation	Program Counter \leftarrow Stack $ACC \leftarrow x$
Affected flag(s)	None
RETI	Return from interrupt
Description	The Program Counter is restored from the stack and the interrupts are re-enabled by setting the EMI bit. EMI is the master interrupt global enable bit. If an interrupt was pending when the RETI instruction is executed, the pending Interrupt routine will be processed before returning to the main program.
Operation	Program Counter \leftarrow Stack $EMI \leftarrow 1$
Affected flag(s)	None
RL [m]	Rotate Data Memory left
Description	The contents of the specified Data Memory are rotated left by 1 bit with bit 7 rotated into bit 0.
Operation	$[m].(i+1) \leftarrow [m].i; (i = 0\sim 6)$ $[m].0 \leftarrow [m].7$
Affected flag(s)	None
RLA [m]	Rotate Data Memory left with result in ACC
Description	The contents of the specified Data Memory are rotated left by 1 bit with bit 7 rotated into bit 0. The rotated result is stored in the Accumulator and the contents of the Data Memory remain unchanged.
Operation	$ACC.(i+1) \leftarrow [m].i; (i = 0\sim 6)$ $ACC.0 \leftarrow [m].7$
Affected flag(s)	None

RLC [m]	Rotate Data Memory left through Carry
Description	The contents of the specified Data Memory and the carry flag are rotated left by 1 bit. Bit 7 replaces the Carry bit and the original carry flag is rotated into bit 0.
Operation	$[m].(i+1) \leftarrow [m].i; (i = 0\sim6)$ $[m].0 \leftarrow C$ $C \leftarrow [m].7$
Affected flag(s)	C
RLCA [m]	Rotate Data Memory left through Carry with result in ACC
Description	Data in the specified Data Memory and the carry flag are rotated left by 1 bit. Bit 7 replaces the Carry bit and the original carry flag is rotated into the bit 0. The rotated result is stored in the Accumulator and the contents of the Data Memory remain unchanged.
Operation	$ACC.(i+1) \leftarrow [m].i; (i = 0\sim6)$ $ACC.0 \leftarrow C$ $C \leftarrow [m].7$
Affected flag(s)	C
RR [m]	Rotate Data Memory right
Description	The contents of the specified Data Memory are rotated right by 1 bit with bit 0 rotated into bit 7.
Operation	$[m].i \leftarrow [m].(i+1); (i = 0\sim6)$ $[m].7 \leftarrow [m].0$
Affected flag(s)	None
RRA [m]	Rotate Data Memory right with result in ACC
Description	Data in the specified Data Memory and the carry flag are rotated right by 1 bit with bit 0 rotated into bit 7. The rotated result is stored in the Accumulator and the contents of the Data Memory remain unchanged.
Operation	$ACC.i \leftarrow [m].(i+1); (i = 0\sim6)$ $ACC.7 \leftarrow [m].0$
Affected flag(s)	None
RRC [m]	Rotate Data Memory right through Carry
Description	The contents of the specified Data Memory and the carry flag are rotated right by 1 bit. Bit 0 replaces the Carry bit and the original carry flag is rotated into bit 7.
Operation	$[m].i \leftarrow [m].(i+1); (i = 0\sim6)$ $[m].7 \leftarrow C$ $C \leftarrow [m].0$
Affected flag(s)	C
RRCA [m]	Rotate Data Memory right through Carry with result in ACC
Description	Data in the specified Data Memory and the carry flag are rotated right by 1 bit. Bit 0 replaces the Carry bit and the original carry flag is rotated into bit 7. The rotated result is stored in the Accumulator and the contents of the Data Memory remain unchanged.
Operation	$ACC.i \leftarrow [m].(i+1); (i = 0\sim6)$ $ACC.7 \leftarrow C$ $C \leftarrow [m].0$
Affected flag(s)	C

SBC A,[m]	Subtract Data Memory from ACC with Carry
Description	The contents of the specified Data Memory and the complement of the carry flag are subtracted from the Accumulator. The result is stored in the Accumulator. Note that if the result of subtraction is negative, the C flag will be cleared to 0, otherwise if the result is positive or zero, the C flag will be set to 1.
Operation	$ACC \leftarrow ACC - [m] - \bar{C}$
Affected flag(s)	OV, Z, AC, C
SBCM A,[m]	Subtract Data Memory from ACC with Carry and result in Data Memory
Description	The contents of the specified Data Memory and the complement of the carry flag are subtracted from the Accumulator. The result is stored in the Data Memory. Note that if the result of subtraction is negative, the C flag will be cleared to 0, otherwise if the result is positive or zero, the C flag will be set to 1.
Operation	$[m] \leftarrow ACC - [m] - \bar{C}$
Affected flag(s)	OV, Z, AC, C
SDZ [m]	Skip if decrement Data Memory is 0
Description	The contents of the specified Data Memory are first decremented by 1. If the result is 0 the following instruction is skipped. As this requires the insertion of a dummy instruction while the next instruction is fetched, it is a two cycle instruction. If the result is not 0 the program proceeds with the following instruction.
Operation	$[m] \leftarrow [m] - 1$ Skip if $[m] = 0$
Affected flag(s)	None
SDZA [m]	Skip if decrement Data Memory is zero with result in ACC
Description	The contents of the specified Data Memory are first decremented by 1. If the result is 0, the following instruction is skipped. The result is stored in the Accumulator but the specified Data Memory contents remain unchanged. As this requires the insertion of a dummy instruction while the next instruction is fetched, it is a two cycle instruction. If the result is not 0, the program proceeds with the following instruction.
Operation	$ACC \leftarrow [m] - 1$ Skip if $ACC = 0$
Affected flag(s)	None
SET [m]	Set Data Memory
Description	Each bit of the specified Data Memory is set to 1.
Operation	$[m] \leftarrow FFH$
Affected flag(s)	None
SET [m].i	Set bit of Data Memory
Description	Bit i of the specified Data Memory is set to 1.
Operation	$[m].i \leftarrow 1$
Affected flag(s)	None

SIZ [m]	Skip if increment Data Memory is 0
Description	The contents of the specified Data Memory are first incremented by 1. If the result is 0, the following instruction is skipped. As this requires the insertion of a dummy instruction while the next instruction is fetched, it is a two cycle instruction. If the result is not 0 the program proceeds with the following instruction.
Operation	$[m] \leftarrow [m] + 1$ Skip if $[m] = 0$
Affected flag(s)	None
SIZA [m]	Skip if increment Data Memory is zero with result in ACC
Description	The contents of the specified Data Memory are first incremented by 1. If the result is 0, the following instruction is skipped. The result is stored in the Accumulator but the specified Data Memory contents remain unchanged. As this requires the insertion of a dummy instruction while the next instruction is fetched, it is a two cycle instruction. If the result is not 0 the program proceeds with the following instruction.
Operation	$ACC \leftarrow [m] + 1$ Skip if $ACC = 0$
Affected flag(s)	None
SNZ [m].i	Skip if bit i of Data Memory is not 0
Description	If bit i of the specified Data Memory is not 0, the following instruction is skipped. As this requires the insertion of a dummy instruction while the next instruction is fetched, it is a two cycle instruction. If the result is 0 the program proceeds with the following instruction.
Operation	Skip if $[m].i \neq 0$
Affected flag(s)	None
SUB A,[m]	Subtract Data Memory from ACC
Description	The specified Data Memory is subtracted from the contents of the Accumulator. The result is stored in the Accumulator. Note that if the result of subtraction is negative, the C flag will be cleared to 0, otherwise if the result is positive or zero, the C flag will be set to 1.
Operation	$ACC \leftarrow ACC - [m]$
Affected flag(s)	OV, Z, AC, C
SUBM A,[m]	Subtract Data Memory from ACC with result in Data Memory
Description	The specified Data Memory is subtracted from the contents of the Accumulator. The result is stored in the Data Memory. Note that if the result of subtraction is negative, the C flag will be cleared to 0, otherwise if the result is positive or zero, the C flag will be set to 1.
Operation	$[m] \leftarrow ACC - [m]$
Affected flag(s)	OV, Z, AC, C
SUB A,x	Subtract immediate data from ACC
Description	The immediate data specified by the code is subtracted from the contents of the Accumulator. The result is stored in the Accumulator. Note that if the result of subtraction is negative, the C flag will be cleared to 0, otherwise if the result is positive or zero, the C flag will be set to 1.
Operation	$ACC \leftarrow ACC - x$
Affected flag(s)	OV, Z, AC, C

SWAP [m]	Swap nibbles of Data Memory
Description	The low-order and high-order nibbles of the specified Data Memory are interchanged.
Operation	$[m].3 \sim [m].0 \leftrightarrow [m].7 \sim [m].4$
Affected flag(s)	None
SWAPA [m]	Swap nibbles of Data Memory with result in ACC
Description	The low-order and high-order nibbles of the specified Data Memory are interchanged. The result is stored in the Accumulator. The contents of the Data Memory remain unchanged.
Operation	$ACC.3 \sim ACC.0 \leftarrow [m].7 \sim [m].4$ $ACC.7 \sim ACC.4 \leftarrow [m].3 \sim [m].0$
Affected flag(s)	None
SZ [m]	Skip if Data Memory is 0
Description	If the contents of the specified Data Memory is 0, the following instruction is skipped. As this requires the insertion of a dummy instruction while the next instruction is fetched, it is a two cycle instruction. If the result is not 0 the program proceeds with the following instruction.
Operation	Skip if $[m] = 0$
Affected flag(s)	None
SZA [m]	Skip if Data Memory is 0 with data movement to ACC
Description	The contents of the specified Data Memory are copied to the Accumulator. If the value is zero, the following instruction is skipped. As this requires the insertion of a dummy instruction while the next instruction is fetched, it is a two cycle instruction. If the result is not 0 the program proceeds with the following instruction.
Operation	$ACC \leftarrow [m]$ Skip if $[m] = 0$
Affected flag(s)	None
SZ [m].i	Skip if bit i of Data Memory is 0
Description	If bit i of the specified Data Memory is 0, the following instruction is skipped. As this requires the insertion of a dummy instruction while the next instruction is fetched, it is a two cycle instruction. If the result is not 0, the program proceeds with the following instruction.
Operation	Skip if $[m].i = 0$
Affected flag(s)	None
TABRDC [m]	Read table (current page) to TBLH and Data Memory
Description	The low byte of the program code (current page) addressed by the table pointer (TBLP) is moved to the specified Data Memory and the high byte moved to TBLH.
Operation	$[m] \leftarrow$ program code (low byte) $TBLH \leftarrow$ program code (high byte)
Affected flag(s)	None
TABRDL [m]	Read table (last page) to TBLH and Data Memory
Description	The low byte of the program code (last page) addressed by the table pointer (TBLP) is moved to the specified Data Memory and the high byte moved to TBLH.
Operation	$[m] \leftarrow$ program code (low byte) $TBLH \leftarrow$ program code (high byte)
Affected flag(s)	None

XOR A,[m]	Logical XOR Data Memory to ACC
Description	Data in the Accumulator and the specified Data Memory perform a bitwise logical XOR operation. The result is stored in the Accumulator.
Operation	ACC ← ACC "XOR" [m]
Affected flag(s)	Z
XORM A,[m]	Logical XOR ACC to Data Memory
Description	Data in the specified Data Memory and the Accumulator perform a bitwise logical XOR operation. The result is stored in the Data Memory.
Operation	[m] ← ACC "XOR" [m]
Affected flag(s)	Z
XOR A,x	Logical XOR immediate data to ACC
Description	Data in the Accumulator and the specified immediate data perform a bitwise logical XOR operation. The result is stored in the Accumulator.
Operation	ACC ← ACC "XOR" x
Affected flag(s)	Z

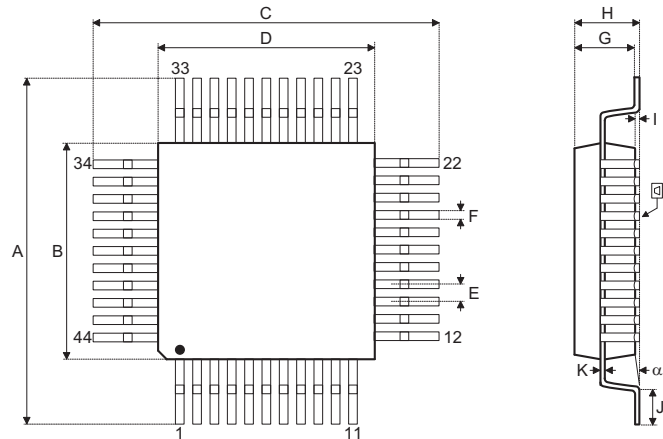
Package Information
44-pin QFP (10mm×10mm) Outline Dimensions

Symbol	Dimensions in inch		
	Min.	Nom.	Max.
A	0.512	—	0.528
B	0.390	—	0.398
C	0.512	—	0.528
D	0.390	—	0.398
E	—	0.031	—
F	—	0.012	—
G	0.075	—	0.087
H	—	—	0.106
I	0.010	—	0.020
J	0.029	—	0.037
K	0.004	—	0.008
L	—	0.004	—
α	0°	—	7°

Symbol	Dimensions in mm		
	Min.	Nom.	Max.
A	13.00	—	13.40
B	9.90	—	10.10
C	13.00	—	13.40
D	9.90	—	10.10
E	—	0.80	—
F	—	0.30	—
G	1.90	—	2.20
H	—	—	2.70
I	0.25	—	0.50
J	0.73	—	0.93
K	0.10	—	0.20
L	—	0.10	—
α	0°	—	7°

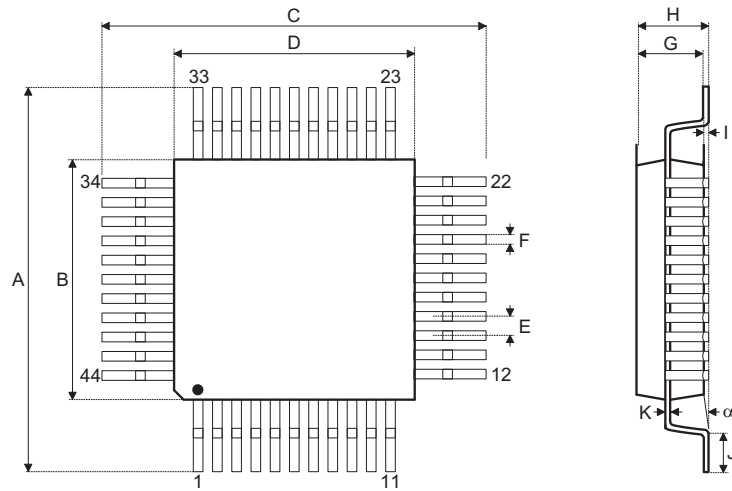
44-pin LQFP (10mm×10mm) (FP3.2mm) Outline Dimensions

Symbol	Dimensions in inch		
	Min.	Nom.	Max.
A	0.512	0.520	0.528
B	0.390	0.394	0.398
C	0.512	0.520	0.528
D	0.390	0.394	0.398
E	—	0.031	—
F	—	0.012	—
G	0.053	0.055	0.057
H	—	—	0.063
I	0.004	—	0.010
J	0.041	0.047	0.053
K	0.004	—	0.008
α	0°	—	7°

Symbol	Dimensions in mm		
	Min.	Nom.	Max.
A	13.00	13.20	13.40
B	9.90	10.00	10.10
C	13.00	13.20	13.40
D	9.90	10.00	10.10
E	—	0.80	—
F	—	0.30	—
G	1.35	1.40	1.45
H	—	—	1.60
I	0.10	—	0.25
J	1.05	1.20	1.35
K	0.10	—	0.25
α	0°	—	7°

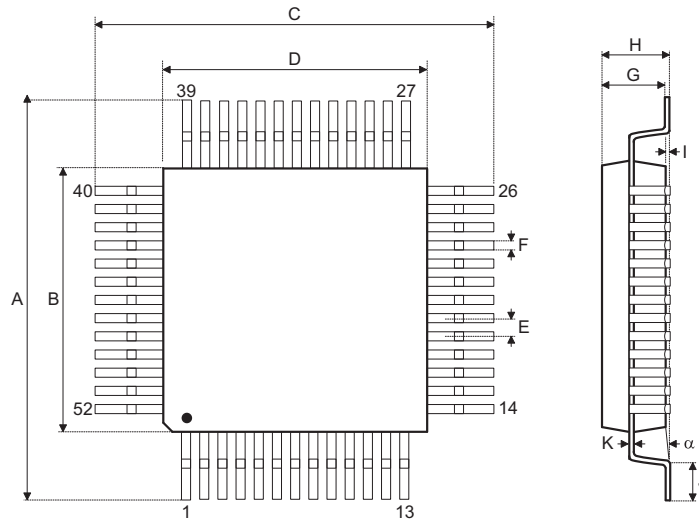
52-pin QFP (14mm×14mm) Outline Dimensions

Symbol	Dimensions in inch		
	Min.	Nom.	Max.
A	0.681	—	0.689
B	0.547	—	0.555
C	0.681	—	0.689
D	0.547	—	0.555
E	—	0.039	—
F	—	0.016	—
G	0.098	—	0.122
H	—	—	0.134
I	—	0.004	—
J	0.029	—	0.041
K	0.004	—	0.008
L	—	0.004	—
α	0°	—	7°

Symbol	Dimensions in mm		
	Min.	Nom.	Max.
A	17.30	—	17.50
B	13.90	—	14.10
C	17.30	—	17.50
D	13.90	—	14.10
E	—	1.00	—
F	—	0.40	—
G	2.50	—	3.10
H	—	—	3.40
I	—	0.10	—
J	0.73	—	1.03
K	0.10	—	0.20
α	0°	—	7°

Holtek Semiconductor Inc. (Headquarters)

No.3, Creation Rd. II, Science Park, Hsinchu, Taiwan
Tel: 886-3-563-1999
Fax: 886-3-563-1189
<http://www.holtek.com.tw>

Holtek Semiconductor Inc. (Taipei Sales Office)

4F-2, No. 3-2, YuanQu St., Nankang Software Park, Taipei 115, Taiwan
Tel: 886-2-2655-7070
Fax: 886-2-2655-7373
Fax: 886-2-2655-7383 (International sales hotline)

Holtek Semiconductor Inc. (Shenzhen Sales Office)

5F, Unit A, Productivity Building, No.5 Gaoxin M 2nd Road, Nanshan District, Shenzhen, China 518057
Tel: 86-755-8616-9908, 86-755-8616-9308
Fax: 86-755-8616-9722

Holtek Semiconductor (USA), Inc. (North America Sales Office)

46729 Fremont Blvd., Fremont, CA 94538, USA
Tel: 1-510-252-9880
Fax: 1-510-252-9885
<http://www.holtek.com>

Copyright © 2010 by HOLTEK SEMICONDUCTOR INC.

The information appearing in this Data Sheet is believed to be accurate at the time of publication. However, Holtek assumes no responsibility arising from the use of the specifications described. The applications mentioned herein are used solely for the purpose of illustration and Holtek makes no warranty or representation that such applications will be suitable without further modification, nor recommends the use of its products for application that may present a risk to human life due to malfunction or otherwise. Holtek's products are not authorized for use as critical components in life support devices or systems. Holtek reserves the right to alter its products without prior notification. For the most up-to-date information, please visit our web site at <http://www.holtek.com.tw>.