

Technical Document

- [Tools Information](#)
- [FAQs](#)
- [Application Note](#)

Features

- Operating voltage: 5V
- Low power consumption at 400mW (Typ.)
- Power-down mode: Under 2mA (Typ.)
- 16-bit 30 MSPS A/D converter
- Guaranteed won't miss codes
- 1~6 programmable gain
- Correlated Double Sampling
- $\pm 250\text{mV}$ programmable offset
- Input clamp circuitry
- Internal voltage reference
- Multiplexed byte-wide output (8+8 format)
- Programmable 3-wire serial interface
- 3V/5V digital I/O compatibility
- 3-channel operation up to 30 MSPS
- 2-channel (Even-Odd) operation up to 30 MSPS
- 1-channel operation up to 25 MSPS
- 28-pin SSOP/SOP package (lead-free on request)

Applications

Flatbed document scanners

Film scanners

Digital color copiers

Multifunction peripherals

General Description

The HT82V26A is a complete analog signal processor for CCD imaging applications. It features a 3-channel architecture designed to sample and condition the outputs of tri-linear color CCD arrays. Each channel consists of an input clamp, Correlated Double Sampler (CDS), offset DAC and Programmable Gain Amplifier (PGA), and a high performance 16-bit A/D converter.

The CDS amplifiers may be disabled for use with sensors such as Contact Image Sensors (CIS) and CMOS active pixel sensors, which do not require CDS.

The 16-bit digital output is multiplexed into an 8-bit output word that is accessed using two read cycles. The internal registers are programmed through a 3-wire serial interface, which provides gain, offset and operating mode adjustments.

The HT82V26A operates from a single 5V power supply, typically consumes 400mW of power.

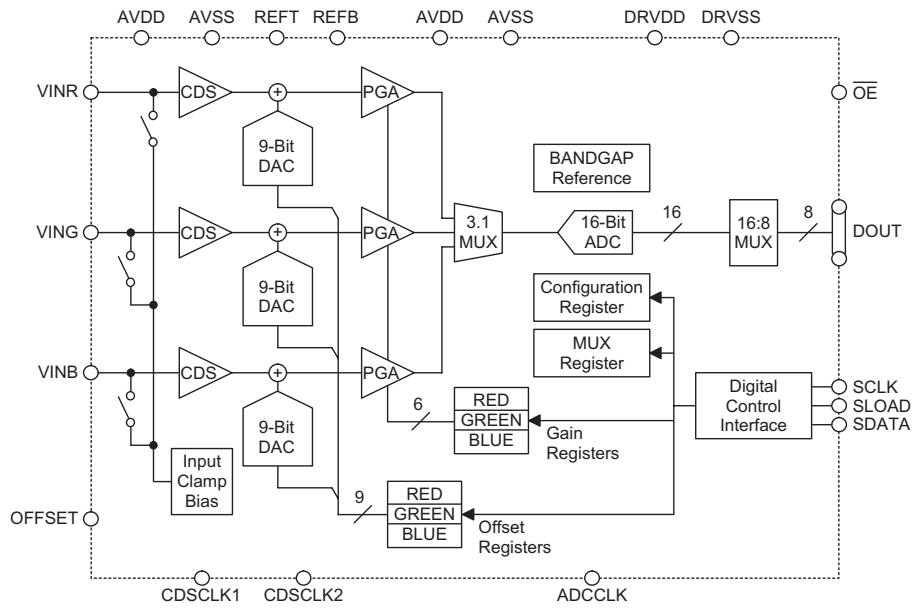
Block Diagram

Pin Assignment

CDSCLK1	1	28	AVDD
CDSCLK2	2	27	AVSS
ADCCLK	3	26	VINR
\overline{OE}	4	25	OFFSET
DRVDD	5	24	VING
DRVSS	6	23	CML
D7 (MSB)	7	22	VINB
D6	8	21	REFT
D5	9	20	REFB
D4	10	19	AVSS
D3	11	18	AVDD
D2	12	17	SLOAD
D1	13	16	SCLK
D0 (LSB)	14	15	SDATA

HT82V26A
-28 SSOP-A/SOP-A

Pin Description

Pin No.	Pin Name	I/O	Description
1	CDSCLK1	DI	CDS reference clock pulse input
2	CDSCLK2	DI	CDS data clock pulse input
3	ADCCLK	DI	A/D sample clock input for 3-channels mode
4	\overline{OE}	DI	Output enable, active low
5	DRVDD	P	Digital driver power
6	DRVSS	P	Digital driver ground
7~14	D7~D0	DO	Digital data output
15	SDATA	DI/DO	Serial data input/output
16	SCLK	DI	Clock input for serial interface
17	SLOAD	DI	Serial interface load pulse
19, 27	AVSS	P	Analog ground
18, 28	AVDD	P	Analog supply
20	REFB	AO	Reference decoupling
21	REFT	AO	Reference decoupling
22	VINB	AI	Analog input, blue
23	CML	AO	Internal reference output
24	VING	AI	Analog input, green
25	OFFSET	AO	Clamp bias level decoupling
26	VINR	AI	Analog input, red

Absolute Maximum Ratings

Supply Voltage	$V_{SS}-0.3V$ to $V_{SS}+5.5V$	Storage Temperature	$-50^{\circ}C$ to $125^{\circ}C$
Input Voltage	$V_{SS}-0.3V$ to $V_{DD}+0.3V$	Operating Temperature	$-25^{\circ}C$ to $75^{\circ}C$

Note: These are stress ratings only. Stresses exceeding the range specified under "Absolute Maximum Ratings" may cause substantial damage to the device. Functional operation of this device at other conditions beyond those listed in the specification is not implied and prolonged exposure to extreme conditions may affect device reliability.

D.C. Characteristics

Symbol	Parameter	Test Conditions		Min.	Typ.	Max.	Unit
		V_{DD}	Conditions				
Logic Inputs							
V_{IH}	High Level Input Voltage (CDSCLK1, CDSCLK2, ADCCLK, \overline{OE} , SCK, SLOAD)	—	—	2	—	—	V
V_{IL}	Low Level Input Voltage (CDSCLK1, CDSCLK2, ADCCLK, \overline{OE} , SCK, SLOAD)	—	—	—	—	0.8	V
V_{IH1}	High Level Input Voltage (SDATA)	—	—	2.5	—	—	V
V_{IL1}	Low Level Input Voltage (SDATA)	—	—	—	—	1.5	V
I_{IH}	High Level Input Current	—	—	—	10	—	μA
I_{IL}	Low Level Input Current	—	—	—	10	—	μA
C_{IN}	Input Capacitance	—	—	—	10	—	pF

Symbol	Parameter	Test Conditions		Min.	Typ.	Max.	Unit
		V _{DD}	Conditions				
Logic Outputs							
V _{OH}	High Level Output Voltage (SDATA, D0-D7)	—	—	DRV _{DD} -0.5	—	—	V
V _{OL}	Low Level Output Voltage (SDATA, D0-D7)	—	—	—	—	0.5	V
I _{OH}	High Level Output Current	—	—	—	1	—	mA
I _{OL}	Low Level Output Current	—	—	—	1	—	mA

A.C. Characteristics

Symbol	Parameter	Test Conditions		Min.	Typ.	Max.	Unit
		V _{DD}	Conditions				
Power Supplies							
V _{ADD}	AVDD	—	—	4.75	5	5.25	V
V _{DRDD}	DRVDD	—	—	3	5	5.25	V
Maximum Conversion Rate							
t _{MAX3}	3-channel Mode with CDS	—	—	30	—	—	MSPS
t _{MAX2}	2-channel Mode with CDS	—	—	30	—	—	MSPS
t _{MAX1}	1-channel Mode with CDS	—	—	25	—	—	MSPS
Accuracy (Entire Signal Path)							
	ADC Resolution	—	—	—	16	—	Bits
	Integral Nonlinear (INL)	—	—	—	±32	—	LSB
	Differential Nonlinear (DNL)	—	—	-1	—	1	LSB
	Offset Error	—	—	-100	—	100	mV
	Gain Error	—	—	—	5	—	%FSR
Analog Inputs							
R _{FS}	Full-scale Input Range	—	—	—	2.0	—	Vp-p
V _i	Input Limits	—	—	A _{VSS} -0.3	—	A _{VDD} +0.3	V
C _i	Input Capacitance	—	—	—	10	—	pF
I _i	Input Current	—	—	—	10	—	nA
Amplifiers							
	PGA Gain at Minimum	—	—	—	1	—	V/V
	PGA Gain at Maximum	—	—	—	5.85	—	V/V
	PGA Gain Resolution	—	—	—	6	—	Bits
	Programmable Offset at Minimum	—	—	—	-250	—	mV
	Programmable Offset at Maximum	—	—	—	250	—	mV
	Offset Resolution	—	—	—	9	—	Bits
Temperature Range							
t _A	Operating	—	—	0	—	70	°C
Power Consumption							
P _{tot}	Total Power Consumption	—	—	—	400	—	mW

Timing Specification

Symbol	Parameter	Min.	Typ.	Max.	Unit
Clock Parameters					
t _{PRA}	3-channel pixel rate	100	—	—	ns
t _{PRB}	2-channel (Even-Odd) pixel rate	66	—	—	ns
t _{PRC}	1-channel pixel rate	40	—	—	ns
t _{ADCLK}	ADCCLK Pulse Width	16	—	—	ns
t _{C1}	CDSCLK1 Pulse Width	12	—	—	ns
t _{C2}	CDSCLK2 Pulse Width	12	—	—	ns
t _{C1C2}	CDSCLK1 Falling to CDSCLK2 Rising	0	—	—	ns
t _{ADC1}	ADCCLK Rising to CDSCLK1 Falling	0	—	—	ns
t _{ADC2}	ADCCLK Rising to CDSCLK2 Falling	0	—	—	ns
t _{AD}	Analog Sampling Delay	5	—	—	ns
3-Channel Mode Only					
t _{aC2C1}	CDSCLK2 Falling to CDSCLK1 Rising	30	—	—	ns
t _{aC2ADR}	CDSCLK2 Falling to ADCCLK Rising	30	—	—	ns
2-Channel Mode Only					
t _{bC2ADR}	CDSCLK2 Falling to ADCCLK Rising	30	—	—	ns
t _{bC1ADR}	CDSCLK1 Rising to ADCCLK Rising	15	—	—	ns
t _{bC2C1}	CDSCLK2 Falling to CDSCLK1 Rising	15	—	—	ns
1-Channel Mode Only					
t _{cC2C1}	CDSCLK2 Falling to CDSCLK1 Rising	15	—	—	ns
t _{cC1ADF}	CDSCLK1 Rising to ADCCLK Falling	0	—	—	ns
t _{cC2ADR}	CDSCLK2 Falling to CDSCLK1 Rising	20	—	—	ns
Serial Interface					
f _{SCLK}	Maximum SCLK Frequency	10	—	—	MHz
t _{LS}	SLOAD to SCLK Setup Time	10	—	—	ns
t _{LH}	SCLK to SLOAD Hold Time	10	—	—	ns
t _{DS}	SDATA to SCLK Rising Setup Time	10	—	—	ns
t _{DH}	SCLK Rising to SDATA Hold Time	10	—	—	ns
t _{RDV}	Falling to SDATA Valid	10	—	—	ns
Data Output					
t _{OD}	Output Delay	—	8	—	ns
	Latency (Pipeline Delay)	—	9	—	Cycles

Functional Description

Integral Nonlinear (INL)

Integral nonlinear error refers to the deviation of each individual code from a line drawn from zero scale through a positive full scale. The point used as zero scale occurs 1/2 LSB before the first code transition. A positive full scale is defined as a level 1/2 LSB beyond the last code transition. The deviation is measured from the middle of each particular code to the true straight line.

Differential Nonlinear (DNL)

An ideal ADC exhibits code transitions that are exactly 1 LSB apart. DNL is the deviation from this ideal value. Thus every code must have a finite width. No missing codes guaranteed for the 16-bit resolution indicates that all the 65536 codes respectively, are present in the over-all operating range.

Offset Error

The first ADC code transition should occur at a level 1/2 LSB above the nominal zero scale voltage.

The offset error is the deviation of the actual first code transition level from the ideal level.

Gain Error

The last code transition should occur for an analog value of 1/2 LSB below the nominal full-scale voltage.

Gain error is the deviation of the actual difference between the first and the last code transitions and the ideal difference between the first and the last code transitions.

Aperture Delay

The aperture delay is the time delay that occurs when a sampling edge is applied to the HT82V26A until the actual sample of the input signal is held. Both CDSCLK1 and CDSCLK2 sample the input signal during the transition from high to low, so the aperture delay is measured from each clock's falling edge to the instant the actual internal sample is taken.

Internal Register Descriptions

Register Name	Address			Data Bits								
	A2	A1	A0	D8	D7	D6	D5	D4	D3	D2	D1	D0
Configuration	0	0	0	0	0	1	3-CH	CDS on	Clamp Voltage	Enable Power Down	Output Delay	1 byte out
MUX	0	0	1	0	RGB/BGR	Red	Green	Blue	Delay enable	CDSCLK1 delay	CDSCLK2 delay	ADCCLK delay
Red PGA	0	1	0	0	0	0	MSB					LSB
Green PGA	0	1	1	0	0	0	MSB					LSB
Blue PGA	1	0	0	0	0	0	MSB					LSB
Red Offset	1	0	1	MSB								LSB
Green Offset	1	1	0	MSB								LSB
Blue Offset	1	1	1	MSB								LSB

Internal Register Map

Configuration Register

The configuration register controls the HT82V26A's operating mode and bias levels. Bits D6 should always be set high. Bit D5 will configure the HT82V26A for the 3-channel (high) mode of operation. Setting the bit D4 high will enable the CDS mode of operation, and setting this bit low will enable the SHA mode of operation.

Bit D3 sets the dc bias level of the HT82V26A's input clamp. This bit should always be set high for the 4V clamp bias, unless a CCD with a reset feed through transient exceeding 2V is used. Setting the bit D3 low, the clamp voltage is 3V. Bit D2 controls the power-down mode. Setting bit D2 high will place the HT82V26A into a very low power "sleep" mode. All register contents are retained while the HT82V26A is in the power-down state. Setting bit D1 high will configure the HT82V26A for the digital output (D0-D7) delay 2ns. Bit D0 controls the output mode of the HT82V26A. Setting bit D0 high will enable a single byte output mode where only 8 MSBs of the 16b ADC is output. If bit D0 is set low, then the 16b ADC output is multiplexed into two bytes.

D8	D7	D6	D5	D4	D3	D2	D1	D0
Set to 0	Set to 0	Set to 1	3 channels	CDS operation	Clamp bias	Power-down	Output delay	1 byte out (High-byte only)
			1=On*	1=CDS mode*	1=4V*	1=On	1=On	1=On
			0=Off	0=SHA mode	0=3V	0=Off (Normal)*	0=Off*	0=Off*

Configuration Register Settings

Note: * Power-on default value

MUX Register

The MUX register controls the sampling channel order and the 2-channel mode configuration in the HT82V26A. Bits D8 should always be set low. Bit D7 is used when operating in the 3-channel mode or the 2-channel mode. Setting bit D7 high will sequence the MUX to sample the red channel first, then the green channel, and then the blue channel. When in the 3-channel mode, the CDSCLK2 rising edge always resets the MUX to sample the red channel first (see timing diagrams). When bit D7 is set low, the channel order is reversed to blue first, green second, and red third. The CDSCLK2 rising edge will always reset the MUX to sample the blue channel first. Bits D6, D5 and D4 are used when operating in 1 or 2-channel mode. Bit D6 is set high to sample the red channel. Bit D5 is set high to sample the green channel. Bit D4 is set high to sample the blue channel. The MUX will remain stationary during 1-channel mode. The two channel mode is selected by setting two of the channel select bits (D4~D6) high. The MUX samples the channels in the order selected by bit D7. Bits D0~D3 are used for controlling CDSCLK1, CDSCLK2 and ADCCLK internal delay.

D8	D7	D6	D5	D4	D3	D2	D1	D0
Set to 0	MUX Order	Channel Select			Enable Delay	CDS1 Delay	CDS2 Delay	ADCK Delay
	1=R-G-B* 0=B-G-R	1=RED* 0=Off	1=GREEN* 0=Off*	1=BLUE* 0=Off*	0=Off 1=On*	0=2ns* 1=4ns	0=2ns* 1=4ns	0=0ns* 1=2ns

MUX Register Settings

Note: * Power-on default value

PGA Gain Registers

There are three PGA registers for use in individually programming the gain in the red, green and blue channels. Bits D8, D7 and D6 in each register must be set low, and bits D5 through D0 control the gain range in 64 increments. See figure for a graph of the PGA gain versus PGA register code. The coding for the PGA registers is a straight binary, with an all zero words corresponding to the minimum gain setting (1x) and an all one word corresponding to the maximum gain setting (5.85x).

The HT82V26A uses one Programmable Gain Amplifier (PGA) for each channel. Each PGA has a gain range from 1x (0dB) to 5.85x (15.3dB), adjustable in 64 steps. The Figure shows the PGA gain as a function of the PGA register code. Although the gain curve is approximately linear in dB, the gain in V/V varies in nonlinear proportion with the register code, according to the following the equation:
$$\text{Gain} = \frac{5.85}{1 + 4.85x\left(\frac{63 - G}{63}\right)}$$

Where G is the decimal value of the gain register contents, and varies from 0 to 63.

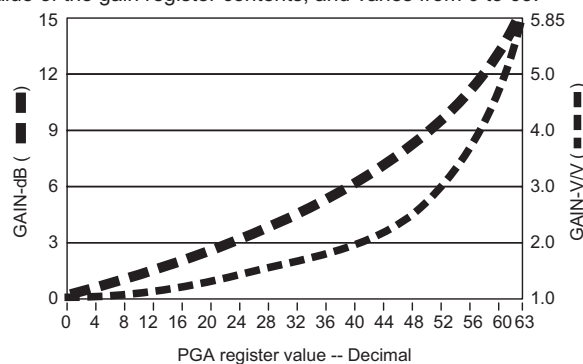
PGA Gain Transfer Function

D8	D7	D6	D5	D4	D3	D2	D1	D0	Gain (V/V)	Gain (dB)
Set to 0	Set to 0	Set to 0	MSB					LSB		
0	0	0	0	0	0	0	0	0*	1.0	0.0
0	0	0	0	0	0	0	0	1	1.013	0.12
					.				.	.
					.				.	.
0	0	0	1	1	1	1	1	0	5.43	14.7
0	0	0	1	1	1	1	1	1	5.85	15.3

PGA Gain Register Settings

Note: * Power-on default value

Offset Registers

There are three offset registers for use in individually programming the offset in the red, green, and blue channels. Bits D8 through D0 control the offset range from -250mV to 250mV in 512 increments.

The coding for the offset registers is sign magnitude, with D8 as the sign bit. The Table shows the offset range as a function of the bits D8 through D0.

D8	D7	D6	D5	D4	D3	D2	D1	D0	Offset (mV)
MSB								LSB	
0	0	0	0	0	0	0	0	0*	0
0	0	0	0	0	0	0	0	1	0.98
					.				.
					.				.
0	1	1	1	1	1	1	1	1	250
1	0	0	0	0	0	0	0	0	0
1	0	0	0	0	0	0	0	1	-0.98
					.				.
					.				.
1	1	1	1	1	1	1	1	1	-250

Note: * Power-on default value

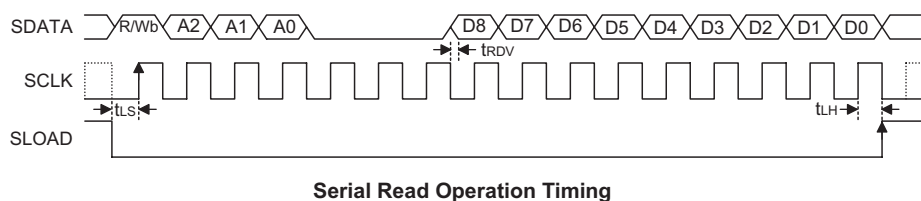
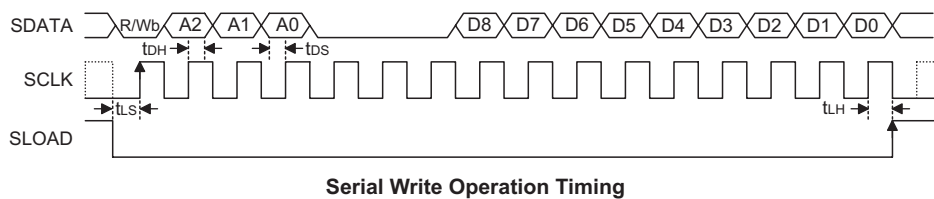
Timing Diagrams

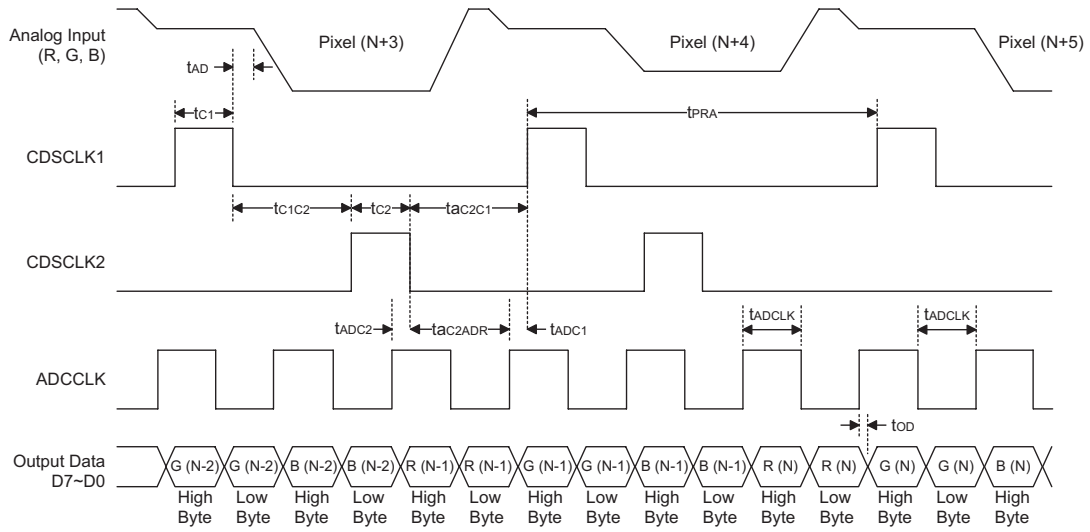

3-Channel CCD Mode Timing (Select R-G-B Mode)

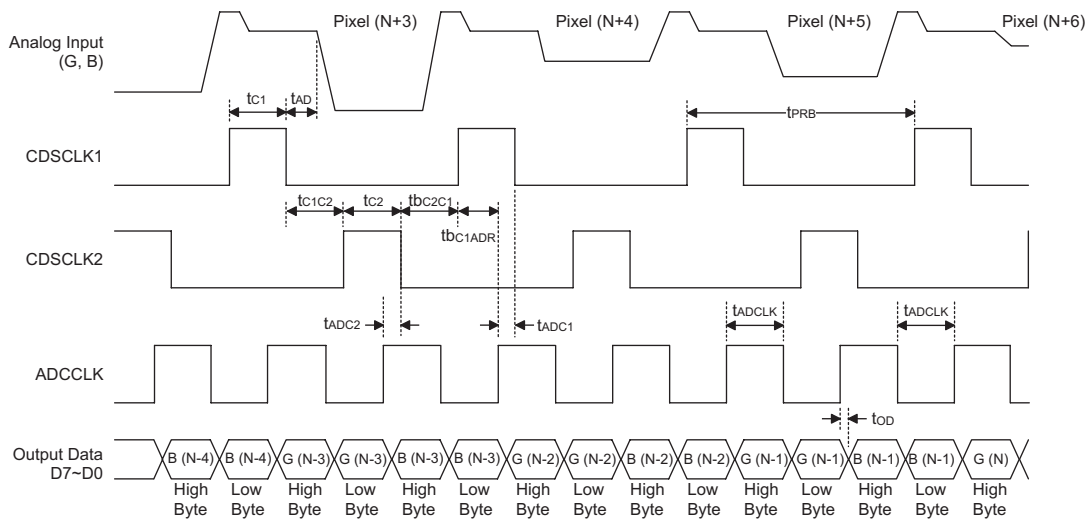

2-Channel CCD Mode Timing (Select G-B Mode)

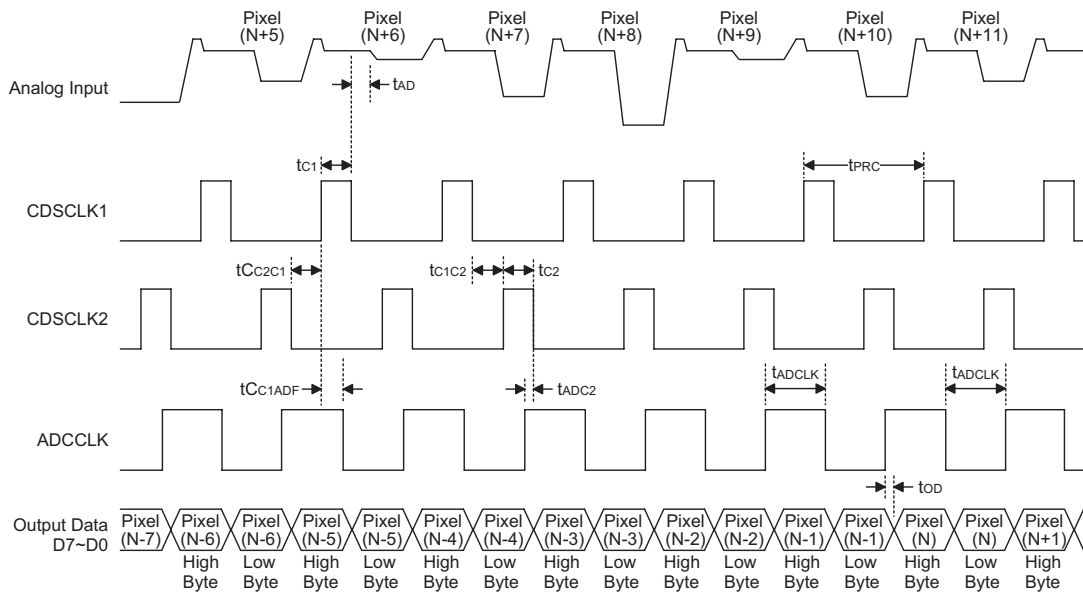

1-Channel CCD Mode Timing

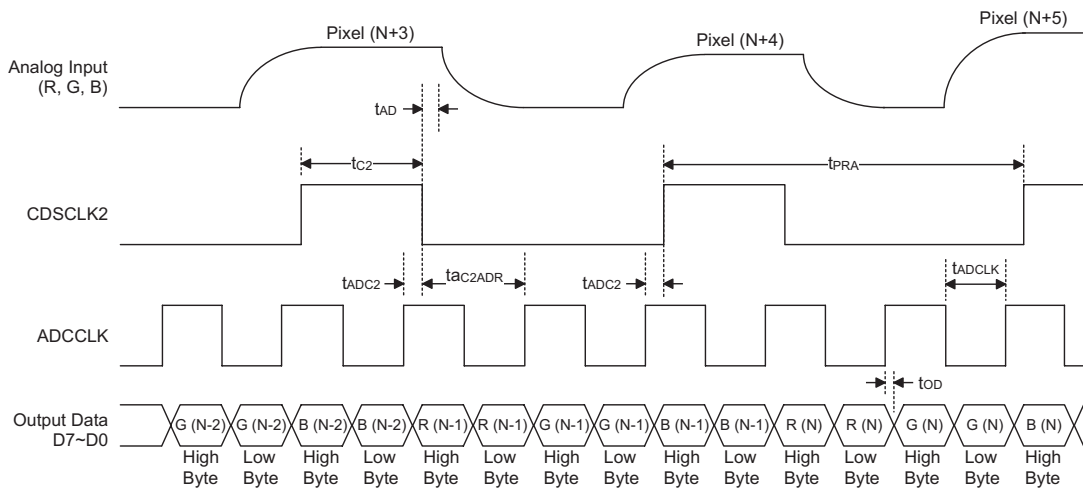

3-Channel SHA Mode Timing (Select R-G-B Mode)

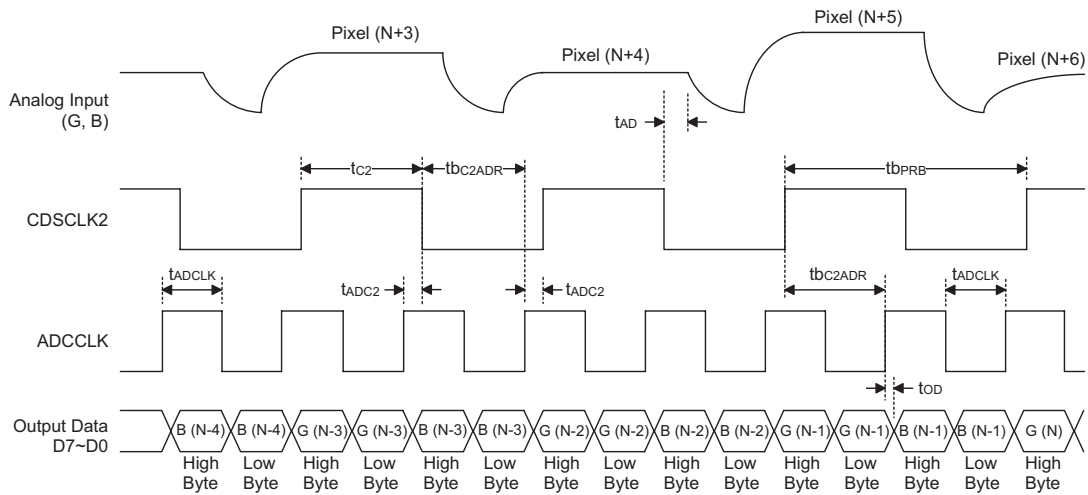

2-Channel SHA Mode Timing (Select G-B Mode)

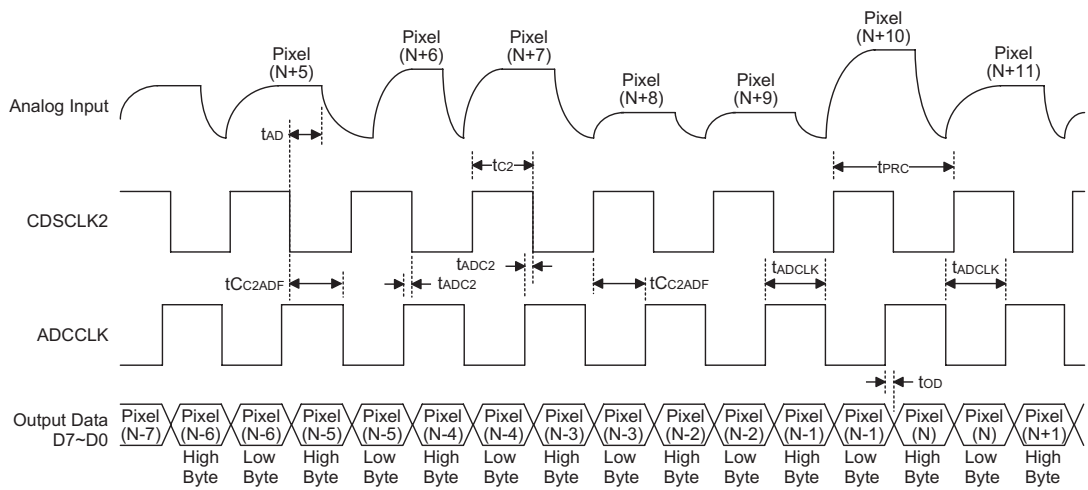

1-Channel SHA Mode Timing

Application Circuits

The recommended circuit configuration for the 3-channel CDS mode operation is shown in the figure below. The recommended input coupling capacitor value is 0.1 μ F.

A single ground plane is recommended for the HT82V26A. A separate power supply may be used for DRVDD, the digital driver supply, but this supply pin should still be decoupled to the same ground plane as with the rest of the HT82V26A. The loading of the digital outputs should be minimized, either by using short traces to the digital ASIC, or by using external digital buffers. To minimize the effect of digital transients during major output code transitions, the falling edge of the CDSCLK2 should occur in coincidence with or before the rising edge of ADCCLK. All 0.1 μ F decoupling capacitors should be located as close as possible to the HT82V26A pins. When operating in a single channel mode, the unused analog inputs should be grounded.

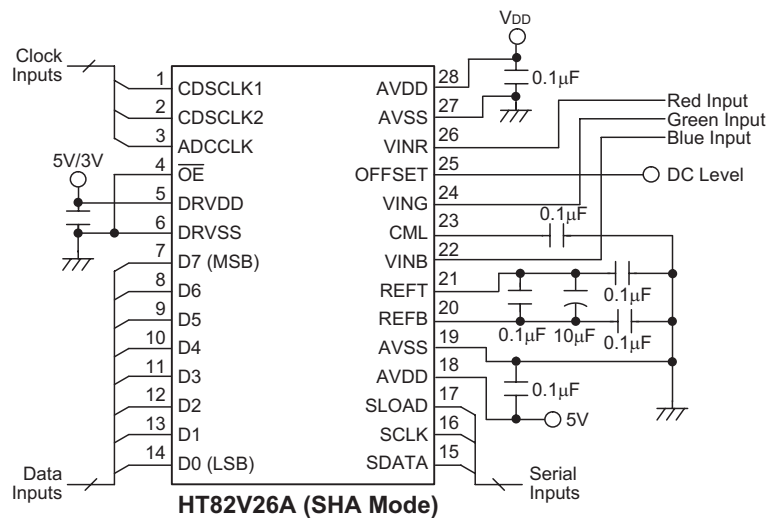
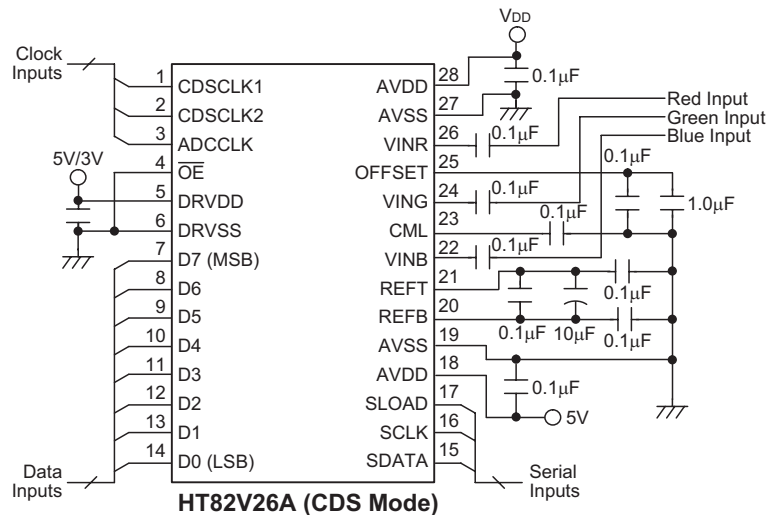

Note: For the 3-channel SHA mode, all of the above considerations also apply for this configuration, except that the analog input signals are directly connected to the HT82V26A without the use of coupling capacitors. The OFFSET pin should be grounded if the inputs to the HT82V26A are to be referenced to ground, or a DC offset voltage should be applied to the OFFSET pin in the case where a coarse offset needs to be removed from the inputs. The analog input signals must already be dc-biased between 0V and 2V, if OFFSET is connected to ground.

Package Information

28-pin SSOP (209mil) Outline Dimensions

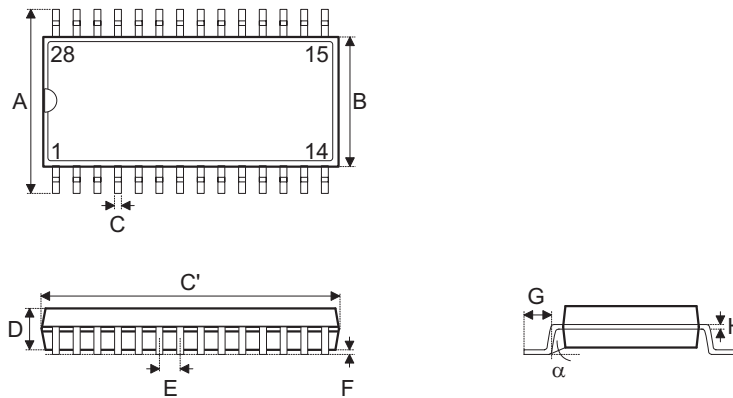

Symbol	Dimensions in mil		
	Min.	Nom.	Max.
A	291	—	323
B	196	—	220
C	9	—	15
C'	396	—	407
D	65	—	73
E	—	25.59	—
F	4	—	10
G	26	—	34
H	4	—	8
α	0°	—	8°

28-pin SOP (300mil) Outline Dimensions

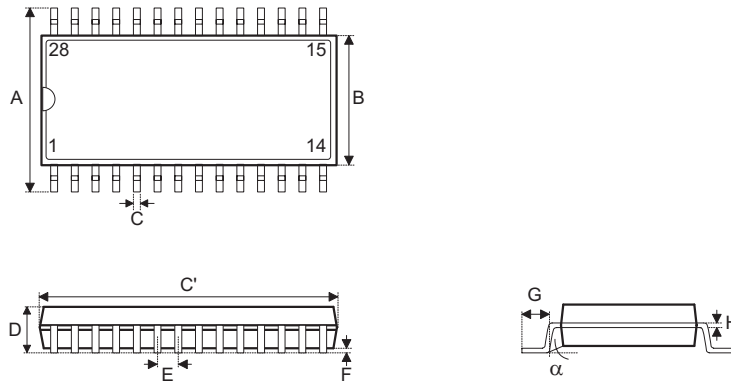

• MS-013

Symbol	Dimensions in mil		
	Min.	Nom.	Max.
A	393	—	419
B	256	—	300
C	12	—	20
C'	697	—	713
D	—	—	104
E	—	50	—
F	4	—	12
G	16	—	50
H	8	—	13
α	0°	—	8°

Product Tape and Reel Specifications

Reel Dimensions

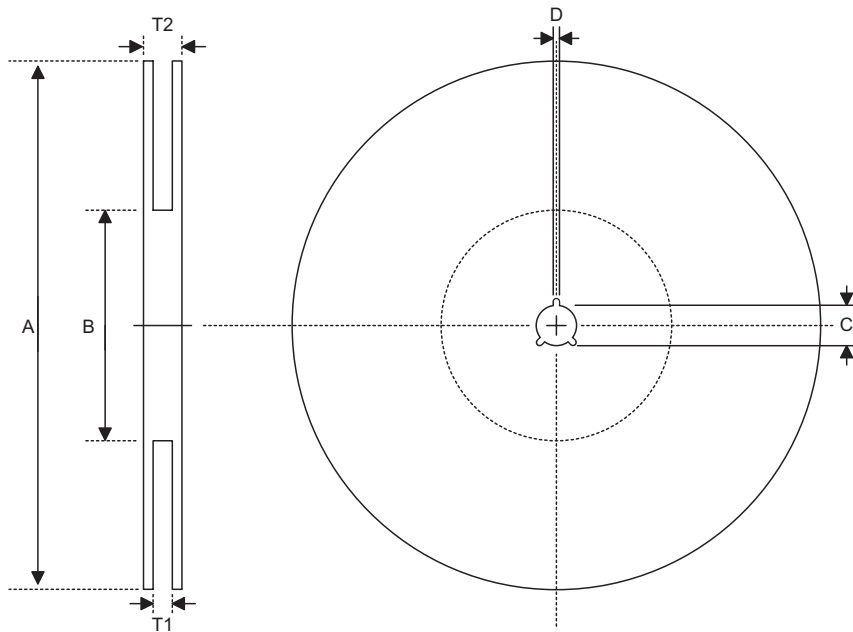

SOP 28W (300mil)

Symbol	Description	Dimensions in mm
A	Reel Outer Diameter	330.0±1.0
B	Reel Inner Diameter	62.0±1.5
C	Spindle Hole Diameter	13.0 ^{+0.5/-0.2}
D	Key Slit Width	2.0±0.5
T1	Space Between Flange	24.8 ^{+0.3/-0.2}
T2	Reel Thickness	30.2±0.2

SSOP 28S (209mil)

Symbol	Description	Dimensions in mm
A	Reel Outer Diameter	330.0±1.0
B	Reel Inner Diameter	100.0±1.5
C	Spindle Hole Diameter	13.0 ^{+0.5/-0.2}
D	Key Slit Width	2.0±0.5
T1	Space Between Flange	28.4 ^{+0.3/-0.2}
T2	Reel Thickness	31.1 (max.)

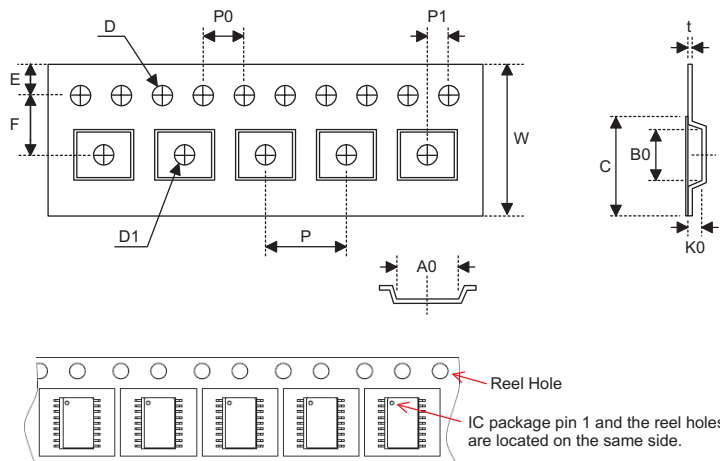
Carrier Tape Dimensions

SOP 28W (300mil)

Symbol	Description	Dimensions in mm
W	Carrier Tape Width	24.0±0.3
P	Cavity Pitch	12.0±0.1
E	Perforation Position	1.75±0.10
F	Cavity to Perforation (Width Direction)	11.5±0.1
D	Perforation Diameter	1.5 ^{+0.1/-0.0}
D1	Cavity Hole Diameter	1.50 ^{+0.25/-0.00}
P0	Perforation Pitch	4.0±0.1
P1	Cavity to Perforation (Length Direction)	2.0±0.1
A0	Cavity Length	10.85±0.10
B0	Cavity Width	18.34±0.10
K0	Cavity Depth	2.97±0.10
t	Carrier Tape Thickness	0.35±0.01
C	Cover Tape Width	21.3±0.1

SSOP 28S (209mil)

Symbol	Description	Dimensions in mm
W	Carrier Tape Width	24.0±0.3
P	Cavity Pitch	12.0±0.1
E	Perforation Position	1.75±0.10
F	Cavity to Perforation (Width Direction)	11.5±0.1
D	Perforation Diameter	1.5 ^{+0.1/-0.0}
D1	Cavity Hole Diameter	1.50 ^{+0.25/-0.00}
P0	Perforation Pitch	4.0±0.2
P1	Cavity to Perforation (Length Direction)	2.0±0.1
A0	Cavity Length	8.4±0.1
B0	Cavity Width	10.65±0.10
K0	Cavity Depth	2.4±0.1
t	Carrier Tape Thickness	0.30±0.05
C	Cover Tape Width	21.3±0.1

Holtek Semiconductor Inc. (Headquarters)

No.3, Creation Rd. II, Science Park, Hsinchu, Taiwan
Tel: 886-3-563-1999
Fax: 886-3-563-1189
<http://www.holtek.com.tw>

Holtek Semiconductor Inc. (Taipei Sales Office)

4F-2, No. 3-2, YuanQu St., Nankang Software Park, Taipei 115, Taiwan
Tel: 886-2-2655-7070
Fax: 886-2-2655-7373
Fax: 886-2-2655-7383 (International sales hotline)

Holtek Semiconductor Inc. (Shanghai Sales Office)

G Room, 3 Floor, No.1 Building, No.2016 Yi-Shan Road, Minhang District, Shanghai, China 201103
Tel: 86-21-5422-4590
Fax: 86-21-5422-4705
<http://www.holtek.com.cn>

Holtek Semiconductor Inc. (Shenzhen Sales Office)

5F, Unit A, Productivity Building, Gaoxin M 2nd, Middle Zone Of High-Tech Industrial Park, ShenZhen, China 518057
Tel: 86-755-8616-9908, 86-755-8616-9308
Fax: 86-755-8616-9722

Holtek Semiconductor Inc. (Beijing Sales Office)

Suite 1721, Jinyu Tower, A129 West Xuan Wu Men Street, Xicheng District, Beijing, China 100031
Tel: 86-10-6641-0030, 86-10-6641-7751, 86-10-6641-7752
Fax: 86-10-6641-0125

Holtek Semiconductor Inc. (Chengdu Sales Office)

709, Building 3, Champagne Plaza, No.97 Dongda Street, Chengdu, Sichuan, China 610016
Tel: 86-28-6653-6590
Fax: 86-28-6653-6591

Holtek Semiconductor (USA), Inc. (North America Sales Office)

46729 Fremont Blvd., Fremont, CA 94538, USA
Tel: 1-510-252-9880
Fax: 1-510-252-9885
<http://www.holtek.com>

Copyright © 2008 by HOLTEK SEMICONDUCTOR INC.

The information appearing in this Data Sheet is believed to be accurate at the time of publication. However, Holtek assumes no responsibility arising from the use of the specifications described. The applications mentioned herein are used solely for the purpose of illustration and Holtek makes no warranty or representation that such applications will be suitable without further modification, nor recommends the use of its products for application that may present a risk to human life due to malfunction or otherwise. Holtek's products are not authorized for use as critical components in life support devices or systems. Holtek reserves the right to alter its products without prior notification. For the most up-to-date information, please visit our web site at <http://www.holtek.com.tw>.