

## 8-Bit Serial-In/Parallel-Out Shift Register

### Features

- Operating voltage: 2.0V~6.0V
- A 8-bit, serial-input to parallel-output shift register
- Gated serial data inputs
- Asynchronous master reset
- Output drive capability: 10 LSTTL Loads
- Outputs Directly Interface to CMOS
- High noise immunity characteristic of CMOS Devices.
- 14-pin DIP/SOP package

### General Description

The HT74164 is identical in pin-out to the LS164. The device inputs are compatible with standard CMOS outputs; with pull-up resistors, they are compatible with LSTTL outputs. The HT74164 is a 8-bit, serial input to parallel-output shift register. Two serial data inputs, A1

and A2, are provided so that one input may be used as a data enable. Data is entered on each rising edge of the clock. The active low asynchronous reset overrides the Clock and Serial Data inputs.

### Block Diagram

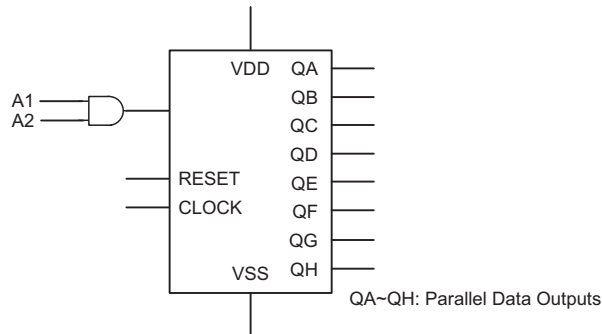

### Pin Assignment

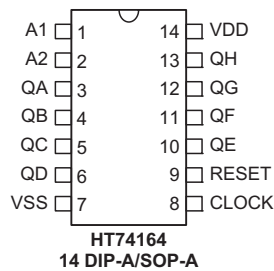

**Pin Description**

Pad No.	Pad Name	I/O	Function
1, 2	A1, A2	I	Serial Data Inputs. Data at these inputs determine the data to be entered into the first stage of the shift register. For a high level to be entered into the shift register both A1 and A2 inputs must be high, thereby allowing one input to be used as a data enable input. When only one serial input is used, the other must be connected to VDD.
3~6, 10~13	QA~QD QE~QH	O	Parallel Shift Register Outputs. The shifted data is presented at these outputs in true, or non-inverted form.
7	VSS	—	Negative power supply, ground
8	CLOCK	I	Shift Register Clock. A positive going transition on this pin shifts the data at each stage to the next stage. The shift register is completely static, allowing clock rates down to DC in a continuous or intermittent mode.
9	RESET	I	Active low, Asynchronous Reset Input. A low voltage applied to this input resets all internal flip flops and sets Outputs QA~QH to the low level state.
14	VDD	—	Positive power supply

**Absolute Maximum Ratings**

Supply Voltage .....	$V_{SS}-0.5V$ to $V_{SS}+7.0V$	Storage Temperature .....	$-65^{\circ}C$ to $150^{\circ}C$
Input Voltage .....	$V_{SS}-1.5V$ to $V_{DD}+1.5V$	Operating Temperature.....	$-40^{\circ}C$ to $85^{\circ}C$
Output Voltage .....	$V_{SS}-0.5V$ to $V_{DD}+0.5V$	Input Current .....	$\pm 20mA$
Output Current.....	$\pm 25mA$	Supply Current .....	$\pm 50mA$
Power Dissipation in Still Air (Plastic or Ceramic DIP).....			750mW
Lead Temperature, 1mm from Case for 10 Seconds (Plastic DIP Package) .....			$260^{\circ}C$

Note: These are stress ratings only. Stresses exceeding the range specified under "Absolute Maximum Ratings" may cause substantial damage to the device. Functional operation of this device at other conditions beyond those listed in the specification is not implied and prolonged exposure to extreme conditions may affect device reliability.

Maximum Ratings are those values beyond which damage to the device may occur.

Functional operation should be restricted to the Recommended Operating Conditions.

Derating: Plastic DIP: 10mW/ $^{\circ}C$  from  $65^{\circ}C$  to  $125^{\circ}C$

**Recommended Operating Conditions**

Supply Voltage .....	$V_{SS}+2.0V$ to $V_{SS}+6.0V$	Operating Temperature.....	$-40^{\circ}C$ to $85^{\circ}C$
Input Voltage .....	0V to $V_{DD}$		
Input Rise and Fall Time (Figure 1): VDD=2.0V .....			0 ~ 1000ns
Input Rise and Fall Time (Figure 1): VDD=4.5V .....			0 ~ 500ns
Input Rise and Fall Time (Figure 1): VDD=6.0V .....			0 ~ 400ns

**D.C. Characteristics**

Ta=25°C

Symbol	Parameter	Test Conditions		Min.	Typ.	Max.	Unit	
		V <sub>DD</sub>	Conditions					
V <sub>DD</sub>	Operating Voltage	—	—	2.0	—	6.0	V	
I <sub>DD</sub>	Operating Current	6.0V	V <sub>IN</sub> =V <sub>DD</sub> or V <sub>SS</sub> , I <sub>OUT</sub> =0μA	—	—	8.0	μA	
V <sub>IH</sub>	Input High Voltage	2.0V	V <sub>OUT</sub> =0.1V or V <sub>DD</sub> -0.1V, I <sub>OUT</sub> ≤ 30μA	1.5	—	—	V	
		4.5V		3.15	—	—	V	
		6.0V		4.2	—	—	V	
V <sub>IL</sub>	Input Low Voltage	2.0V	V <sub>OUT</sub> =0.1V or V <sub>DD</sub> -0.1V, I <sub>OUT</sub> ≤ 30μA	—	—	0.5	V	
		4.5V		—	—	1.35	V	
		6.0V		—	—	1.8	V	
V <sub>OH</sub>	Input Level High Voltage	2.0V	V <sub>IN</sub> =V <sub>IH</sub> or V <sub>IL</sub> , I <sub>OUT</sub> ≤ 30μA	1.9	—	—	V	
		4.5V		4.4	—	—	V	
		6.0V		5.9	—	—	V	
		4.5V		V <sub>IN</sub> =V <sub>IH</sub> or V <sub>IL</sub> , I <sub>OUT</sub> =-6mA	3.84	—	—	V
		6.0V		V <sub>IN</sub> =V <sub>IH</sub> or V <sub>IL</sub> , I <sub>OUT</sub> =-7.8mA	5.34	—	—	V
V <sub>OL</sub>	Input Level Low Voltage	2.0V	V <sub>IN</sub> =V <sub>IH</sub> or V <sub>IL</sub> , I <sub>OUT</sub> =0.02mA	—	—	0.1	V	
		4.5V		—	—	0.1	V	
		6.0V		—	—	0.1	V	
		4.5V		V <sub>IN</sub> =V <sub>IH</sub> or V <sub>IL</sub> , I <sub>OUT</sub> =6mA	—	—	0.26	V
		6.0V		V <sub>IN</sub> =V <sub>IH</sub> or V <sub>IL</sub> , I <sub>OUT</sub> =7.8mA	—	—	0.26	V

**A.C. Characteristics**

Ta=25°C

Symbol	Parameter	V <sub>DD</sub>	Min.	Typ.	Max.	Unit
f <sub>MAX</sub>	Maximum clock Frequency (50% Duty cycle) (See figure 1, figure 4)	2.0V	—	—	5	MHz
		4.5V	—	—	24	MHz
		6.0V	—	—	28	MHz
f <sub>PLH</sub> , f <sub>PLH</sub>	Maximum Propagation Delay, Clock to Q (See figure 1, figure 4)	2.0V	—	—	175	ns
		4.5V	—	—	35	ns
		6.0V	—	—	30	ns
f <sub>PHL</sub>	Maximum Propagation Delay, Reset to Q (See figure 2, figure 4)	2.0V	—	—	205	ns
		4.5V	—	—	41	ns
		6.0V	—	—	35	ns
t <sub>TLH</sub> , t <sub>THL</sub>	Maximum Output Transition Time, Any Output (See figure 1, figure 4)	2.0V	—	—	75	ns
		4.5V	—	—	15	ns
		6.0V	—	—	13	ns
C <sub>IN</sub>	Maximum Input Capacitance	—	—	—	10	pF

Note: For propagation delays with load other than 50pF.

**Timing Requirements**

Ta=25°C

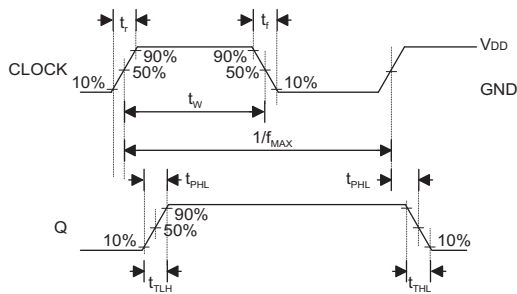
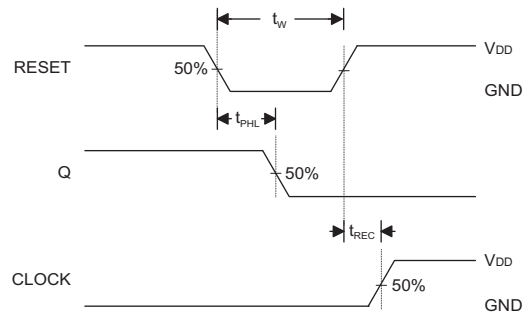
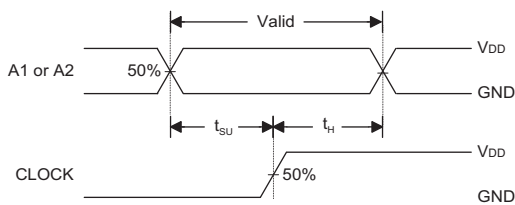
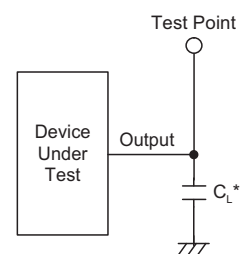

Symbol	Parameter	V <sub>DD</sub>	Min.	Typ.	Max.	Unit
t <sub>SU</sub>	Minimum Setup Time, A1 or A2 to Clock (Figure 3)	2.0V	75	—	—	ns
		4.5V	15	—	—	ns
		6.0V	13	—	—	ns
t <sub>H</sub>	Minimum Hold Time, Clock to A1 or A2 (Figure 3)	2.0V	4	—	—	ns
		4.5V	4	—	—	ns
		6.0V	4	—	—	ns
t <sub>REC</sub>	Minimum Recovery Time, Reset Inactive to Clock (Figure 2 )	2.0V	5	—	—	ns
		4.5V	5	—	—	ns
		6.0V	5	—	—	ns
t <sub>W1</sub>	Minimum Pulse Width, Clock (Figure 1)	2.0V	100	—	—	ns
		4.5V	20	—	—	ns
		6.0V	17	—	—	ns
t <sub>W2</sub>	Minimum Pulse Width, Reset (Figure 1)	2.0V	75	—	—	ns
		4.5V	15	—	—	ns
		6.0V	13	—	—	ns
t <sub>r</sub> , t <sub>f</sub>	Rise/Fall Maximum Input Rise and Fall Times (Figure 1)	2.0V	—	—	1000	ns
		4.5V	—	—	500	ns
		6.0V	—	—	400	ns

**Figure 1**

**Figure 2**

**Figure 3**

Note: \* Including scope

**Figure 4**

**Functional Description**

Input				Output			
Reset	Clock	A1	A2	QA	QB	.....	QL
L	X	X	X	L	L	.....	L
H		X	X	X	X	.....	X
H		H	D	D	QA	.....	QH
H		D	H	D	QA	.....	QH

Note: "D" data input

"QA~QH" data shifted from preceding stage on a rising edge at the clock input.

**Expanded Logic Diagram**

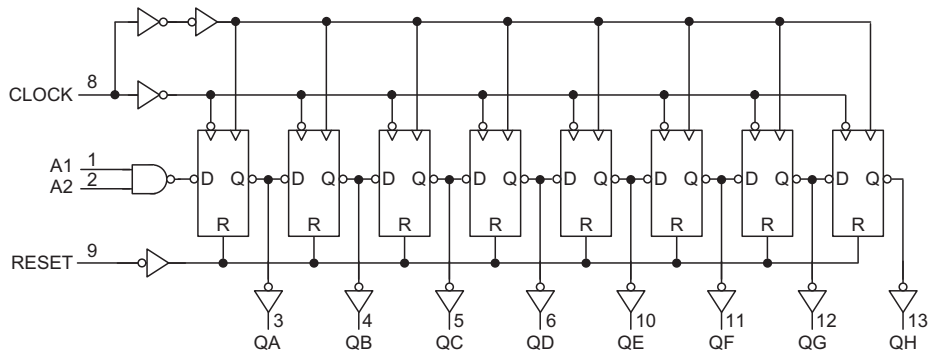

**Timing Diagrams**

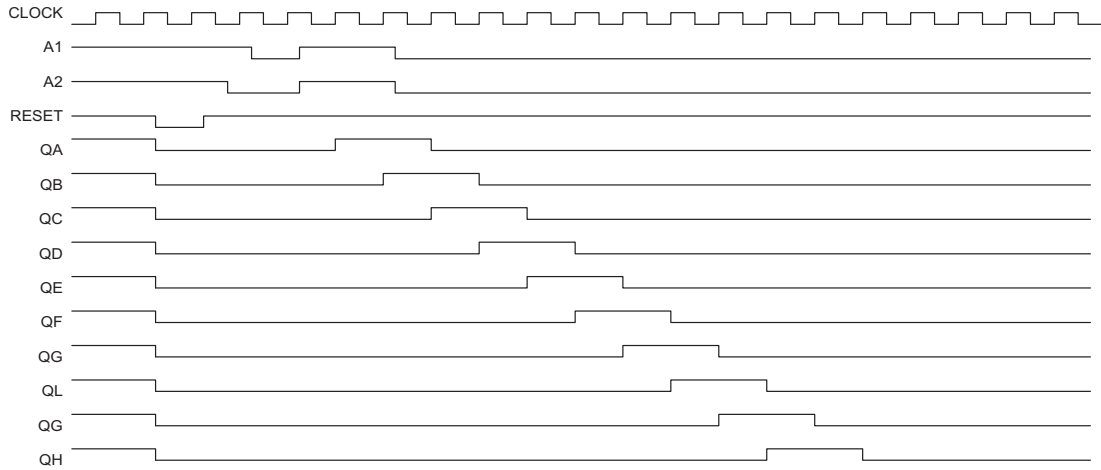

**Package Information**

**14-pin DIP (300mil) Outline Dimensions**

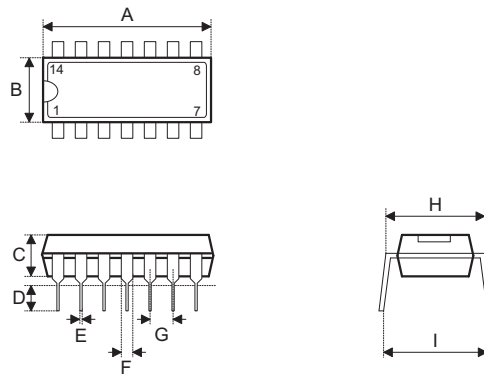

Symbol	Dimensions in mil		
	Min.	Nom.	Max.
A	745	—	775
B	240	—	260
C	125	—	135
D	125	—	145
E	16	—	20
F	50	—	70
G	—	100	—
H	295	—	315
I	—	—	375

**14-pin SOP (150mil) Outline Dimensions**

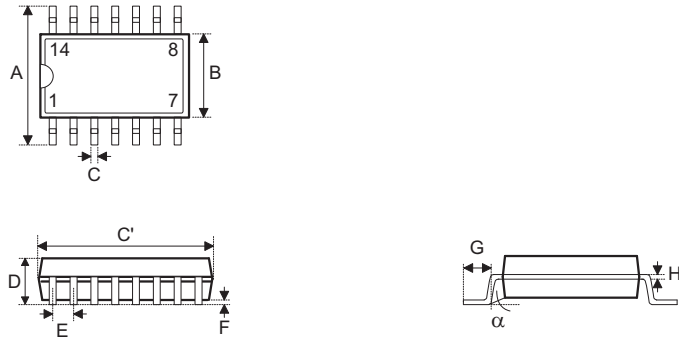

• MS-012

Symbol	Dimensions in mil		
	Min.	Nom.	Max.
A	228	—	244
B	150	—	157
C	12	—	20
C'	337	—	344
D	—	—	69
E	—	50	—
F	4	—	10
G	16	—	50
H	7	—	10
$\alpha$	0°	—	8°

**Product Tape and Reel Specifications**

**Reel Dimensions**

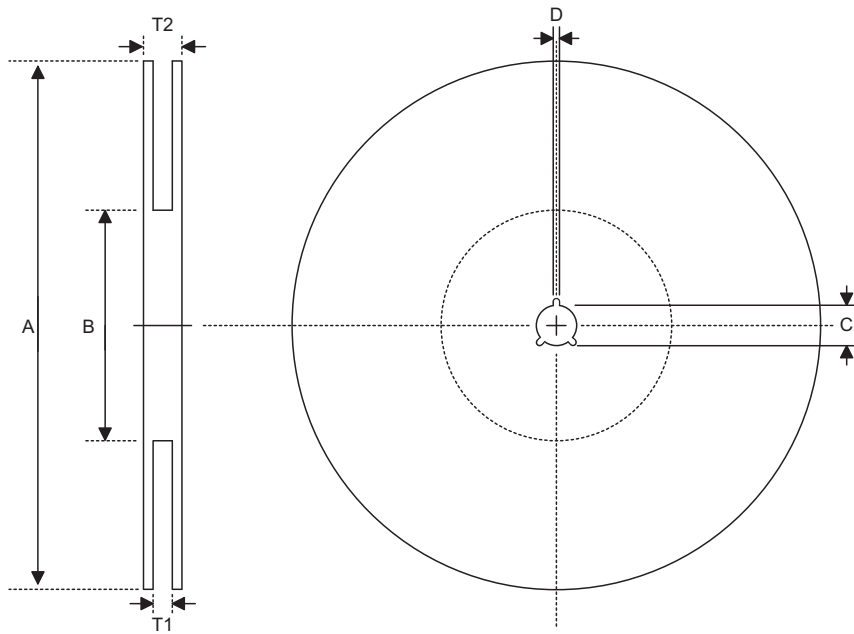

SOP 14N

Symbol	Description	Dimensions in mm
A	Reel Outer Diameter	330.0±1.0
B	Reel Inner Diameter	100.0±1.5
C	Spindle Hole Diameter	13.0 <sup>+0.5/-0.2</sup>
D	Key Slit Width	2.0±0.5
T1	Space Between Flange	16.8 <sup>+0.3/-0.2</sup>
T2	Reel Thickness	22.2±0.2

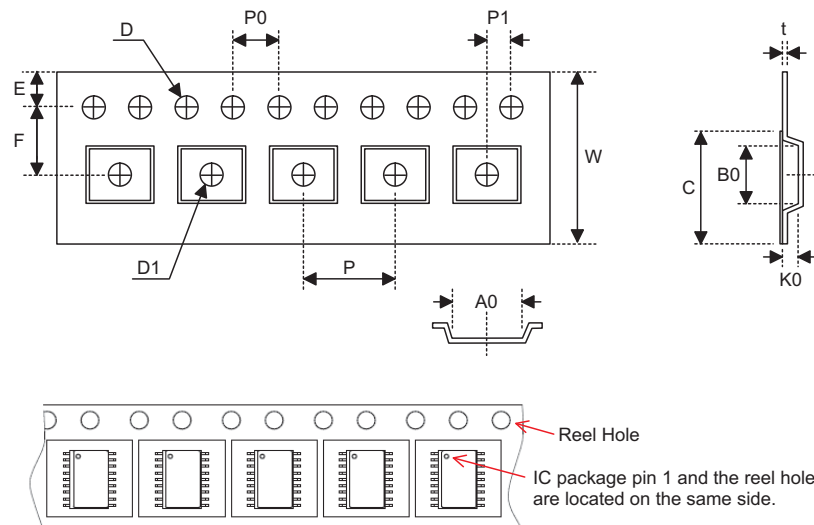
**Carrier Tape Dimensions**

**SOP 14N**

Symbol	Description	Dimensions in mm
W	Carrier Tape Width	16.0 <sup>+0.3/-0.1</sup>
P	Cavity Pitch	8.0±0.1
E	Perforation Position	1.75±0.1
F	Cavity to Perforation (Width Direction)	7.5±0.1
D	Perforation Diameter	1.5 <sup>+0.1/-0.0</sup>
D1	Cavity Hole Diameter	1.50 <sup>+0.25/-0.00</sup>
P0	Perforation Pitch	4.0±0.1
P1	Cavity to Perforation (Length Direction)	2.0±0.1
A0	Cavity Length	6.5±0.1
B0	Cavity Width	9.5±0.1
K0	Cavity Depth	2.1±0.1
t	Carrier Tape Thickness	0.30±0.05
C	Cover Tape Width	13.3±0.1

**Holtek Semiconductor Inc. (Headquarters)**

No.3, Creation Rd. II, Science Park, Hsinchu, Taiwan  
Tel: 886-3-563-1999  
Fax: 886-3-563-1189  
<http://www.holtek.com.tw>

**Holtek Semiconductor Inc. (Taipei Sales Office)**

4F-2, No. 3-2, YuanQu St., Nankang Software Park, Taipei 115, Taiwan  
Tel: 886-2-2655-7070  
Fax: 886-2-2655-7373  
Fax: 886-2-2655-7383 (International sales hotline)

**Holtek Semiconductor Inc. (Shanghai Sales Office)**

G Room, 3 Floor, No.1 Building, No.2016 Yi-Shan Road, Minhang District, Shanghai, China 201103  
Tel: 86-21-5422-4590  
Fax: 86-21-5422-4705  
<http://www.holtek.com.cn>

**Holtek Semiconductor Inc. (Shenzhen Sales Office)**

5F, Unit A, Productivity Building, Gaoxin M 2nd, Middle Zone Of High-Tech Industrial Park, ShenZhen, China 518057  
Tel: 86-755-8616-9908, 86-755-8616-9308  
Fax: 86-755-8616-9722

**Holtek Semiconductor Inc. (Beijing Sales Office)**

Suite 1721, Jinyu Tower, A129 West Xuan Wu Men Street, Xicheng District, Beijing, China 100031  
Tel: 86-10-6641-0030, 86-10-6641-7751, 86-10-6641-7752  
Fax: 86-10-6641-0125

**Holtek Semiconductor (USA), Inc. (North America Sales Office)**

46729 Fremont Blvd., Fremont, CA 94538, USA  
Tel: 1-510-252-9880  
Fax: 1-510-252-9885  
<http://www.holtek.com>

Copyright © 2009 by HOLTEK SEMICONDUCTOR INC.

The information appearing in this Data Sheet is believed to be accurate at the time of publication. However, Holtek assumes no responsibility arising from the use of the specifications described. The applications mentioned herein are used solely for the purpose of illustration and Holtek makes no warranty or representation that such applications will be suitable without further modification, nor recommends the use of its products for application that may present a risk to human life due to malfunction or otherwise. Holtek's products are not authorized for use as critical components in life support devices or systems. Holtek reserves the right to alter its products without prior notification. For the most up-to-date information, please visit our web site at <http://www.holtek.com.tw>.