

### Features

- Operating voltage: 2.7V~5.2V
- LCD driving voltage: 3.0V~5.0V
- Applicable LCD duty from 1/8 to 1/16
- Suitable for various types of LCD panel
- Bias voltage adjustable from an external source

### Applications

- Interface with HT163A
- Electronic dictionaries
- Portable computers
- Remote controllers
- Calculators

### General Description

The HT1602L is a dot matrix LCD segment driver LSI implemented in CMOS technology. The chip contains 40-bit shift register (two 20-bit shift registers), 40-bit latch (two 20-bit latches), 40-bit level shifter, 40-bit 4-level driver and control circuits.

The HT1602L can convert serial data received from an LCD controller parallel data and then

send them out as LCD driving waveforms to the LCD panel. The chip is applicable up to 1/16 duty. Furthermore, the bias voltage which determines the LCD driving voltage can be optionally supplied from an external source, thus the chip is suitable for driving various LCD panel. These special features increase the versatility of the chip.

### Block Diagram

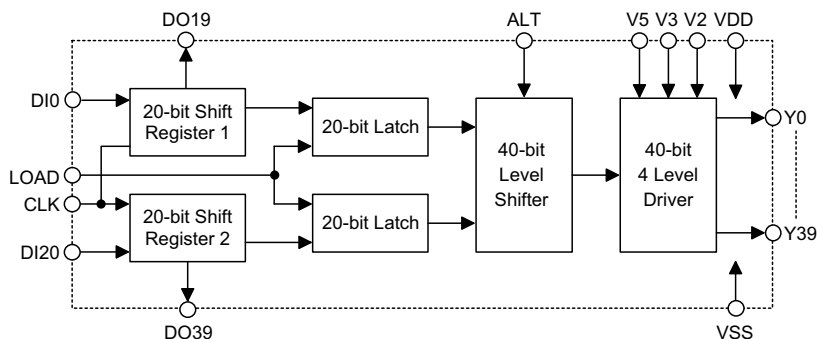

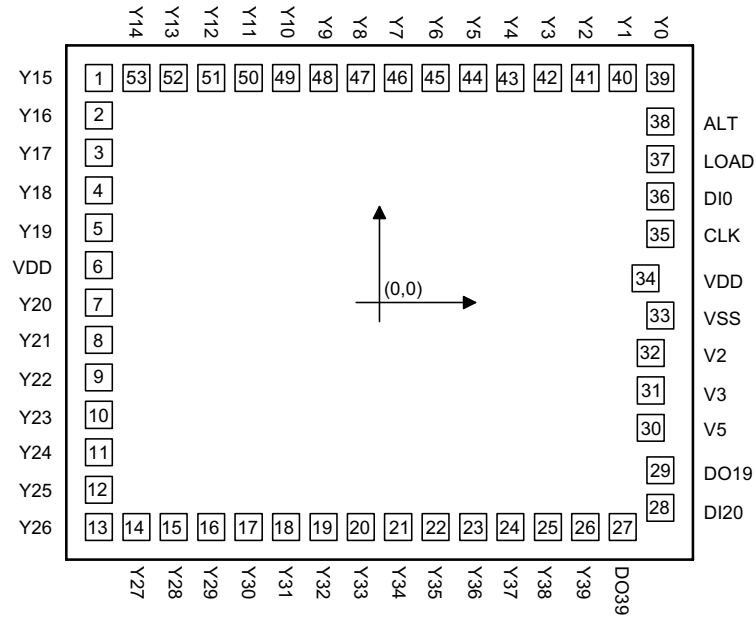
**Pad Assignment**

Chip size:  $87 \times 74 \text{ (mil)}^2$

\* The IC substrate should be connected to VSS in the PCB layout artwork.

**Pad Coordinates**

 Unit:  $\mu\text{m}$ 

Pad No.	X	Y	Pad No.	X	Y
1	-975.00	780.00	28	975.00	-713.00
2	-975.00	650.00	29	975.00	-583.00
3	-975.00	520.00	30	942.50	-435.50
4	-975.00	390.00	31	942.50	-305.50
5	-975.00	260.00	32	942.50	-175.50
6	-975.00	130.00	33	975.00	-45.50
7	-975.00	0.00	34	923.50	84.50
8	-975.00	-130.00	35	975.00	239.00
9	-975.00	-260.00	36	975.00	369.00
10	-975.00	-390.00	37	975.00	499.00
11	-975.00	-520.00	38	975.00	629.00
12	-975.00	-650.00	39	975.00	780.00
13	-975.00	-780.00	40	845.00	780.00
14	-845.00	-780.00	41	715.00	780.00
15	-715.00	-780.00	42	585.00	780.00
16	-585.00	-780.00	43	455.00	780.00
17	-455.00	-780.00	44	325.00	780.00

Pad No.	X	Y	Pad No.	X	Y
18	-325.00	-780.00	45	195.00	780.00
19	-195.00	-780.00	46	65.00	780.00
20	-65.00	-780.00	47	-65.00	780.00
21	65.00	-780.00	48	-195.00	780.00
22	195.00	-780.00	49	-325.00	780.00
23	325.00	-780.00	50	-455.00	780.00
24	455.00	-780.00	51	-585.00	780.00
25	585.00	-780.00	52	-715.00	780.00
26	715.00	-780.00	53	-845.00	780.00
27	845.00	-780.00			

**Pad Description**

Pad No.	Pad Name	I/O	Description
1~5	Y15~Y19	O	LCD driver output for segment*
6	VDD	—	Positive power supply
7~26	Y20~Y39	O	LCD driver output for segment
27	DO39	O	Shift register output pad for the 40th bit data
28	DI20	I	Data input pad of shift register 2
29	DO19	O	Shift register output pad for the 20th bit data
30, 31, 32	V5, V3, V2	I	LCD bias supply voltage
33	VSS	—	Negative power supply, ground
34	VDD	—	Positive power supply
35	CLK	I	Clock pulse input pad for the shift register
36	DI0	I	Data input pad of shift register 1
37	LOAD	I	Latching signal to latch shift register data
38	ALT	I	Alternate signal input pad for LCD driving waveform
39~53	Y0~Y14	O	LCD driver output for segment*

\*: For Y0~Y39, one of VDD, V2, V3 or V5 is selected as a display driving source according to the combination of latched data level and ALT signal. Refer to the following table:

Latched Data	ALT	Display data output level
H	H	V5
	L	V <sub>DD</sub>
L	H	V3
	L	V2

**Absolute Maximum Ratings**

Supply Voltage .....-0.3V to 6.0V      Storage Temperature.....-50°C to 125°C  
 Input Voltage ..... $V_{SS}-0.3V$  to  $V_{DD}+0.3V$       Operating Temperature .....-20°C to 70°C

Note: These are stress ratings only. Stresses exceeding the range specified under "Absolute Maximum Ratings" may cause substantial damage to the device. Functional operation of this device at other conditions beyond those listed in the specification is not implied and prolonged exposure to extreme conditions may affect device reliability.

**D.C. Characteristics**
 $T_a=25^\circ\text{C}$ 

Symbol	Parameter	Test Conditions		Min.	Typ.	Max.	Unit
		$V_{DD}$	Conditions				
$V_{DD}$	Operating Voltage	—	—	2.7	—	5.2	V
$I_{OP}$	Operating Current	5V	No load	—	100	300	$\mu\text{A}$
$I_{DD}$	Standby Current	5V	—	—	1	5	$\mu\text{A}$
$f_{LCD}$	Clock Frequency	5V	—	3.3	—	—	MHz
$t_{wCLK}$	Clock Pulse Width	5V	—	125	—	—	ns
$V_{IL}$	"L" Input Voltage	5V	—	—	—	$0.3V_{DD}$	V
$V_{IH}$	"H" Input Voltage	5V	—	$0.7V_{DD}$	—	—	V
$V_{LCD}$	LCD Driving Voltage	5V	—	3.0	—	5.0	V

Timing Diagrams

1/16 duty and 1/5 bias

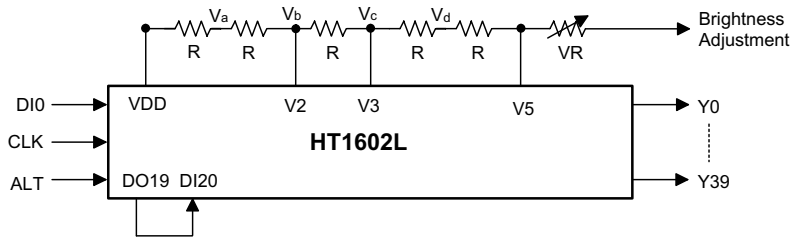
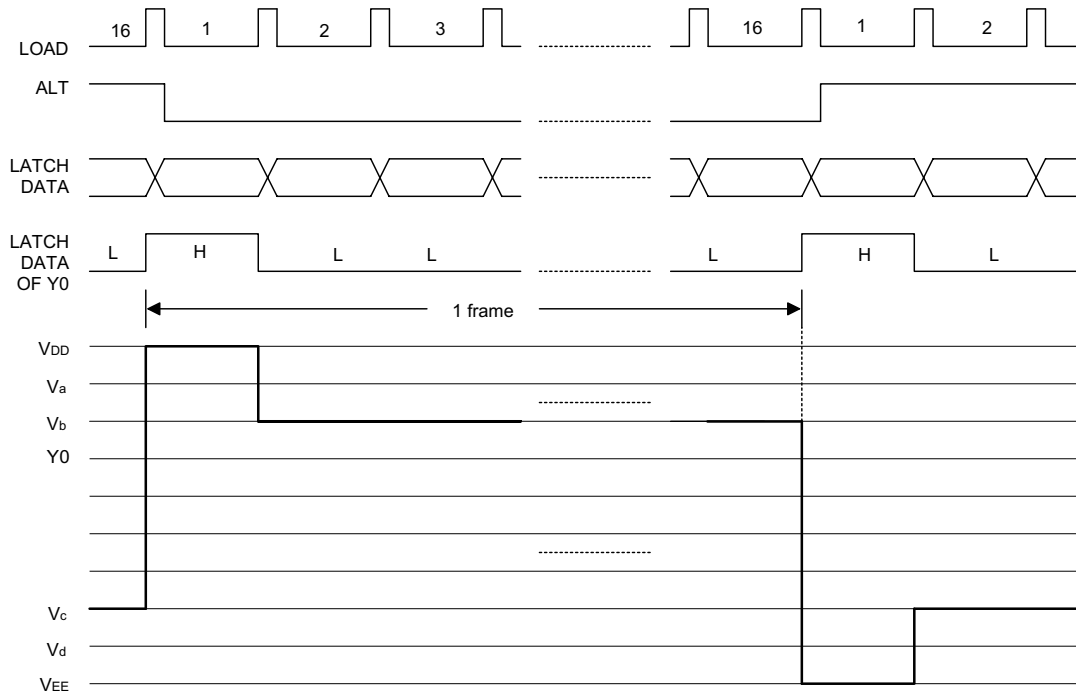

$$\begin{aligned}
 V_a &= V_{DD} - (1/5)V_{LCD} \\
 V_b &= V_{DD} - (2/5)V_{LCD} \\
 V_c &= V_{DD} - (3/5)V_{LCD} \\
 V_d &= V_{DD} - (4/5)V_{LCD} \\
 V_5 &= V_{DD} - V_{LCD} \\
 V_{LCD} &= V_{DD} - V_5; \text{ LCD driving voltage}
 \end{aligned}$$

Application Circuits

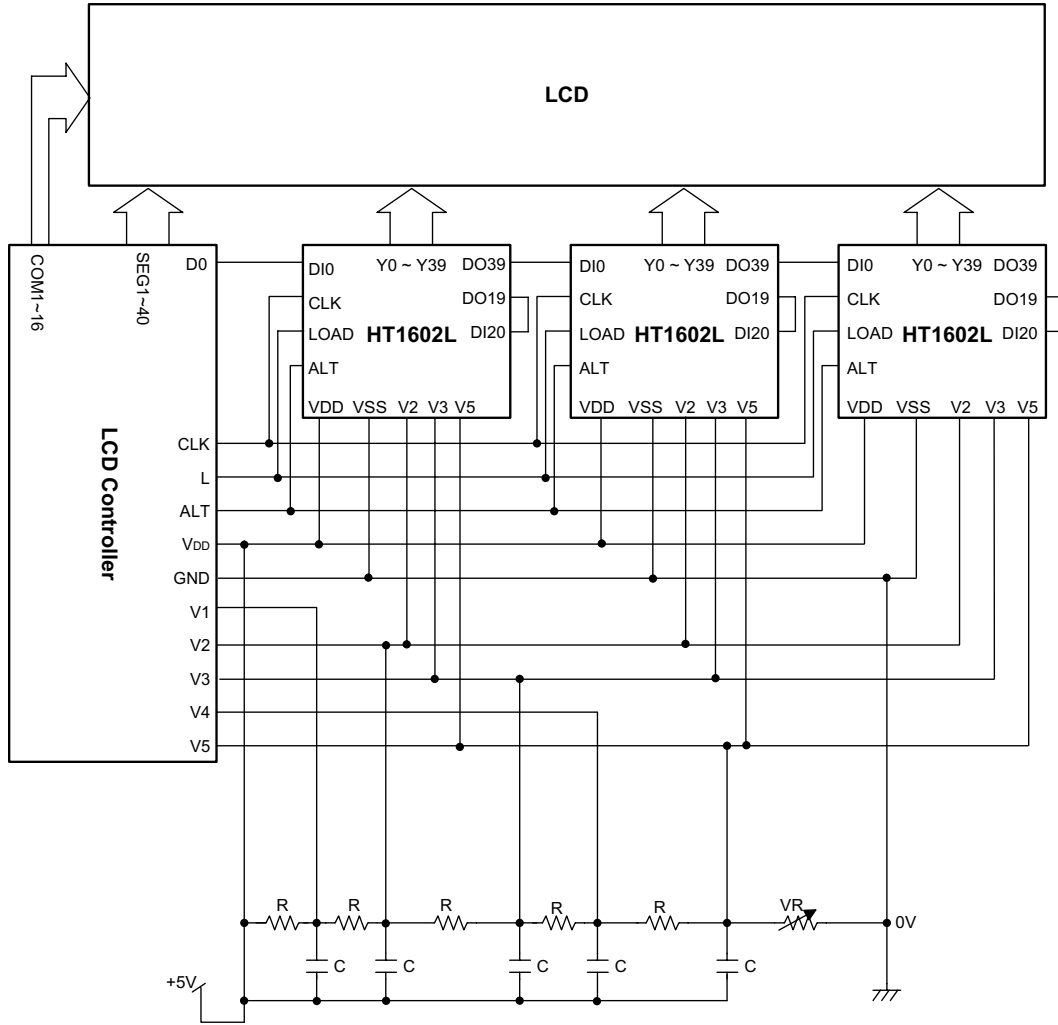

**Holtek Semiconductor Inc. (Headquarters)**

No.3, Creation Rd. II, Science Park, Hsinchu, Taiwan  
Tel: 886-3-563-1999  
Fax: 886-3-563-1189  
<http://www.holtek.com.tw>

**Holtek Semiconductor Inc. (Taipei Sales Office)**

4F-2, No. 3-2, YuanQu St., Nankang Software Park, Taipei 115, Taiwan  
Tel: 886-2-2655-7070  
Fax: 886-2-2655-7373  
Fax: 886-2-2655-7383 (International sales hotline)

**Holtek Semiconductor Inc. (Shanghai Sales Office)**

7th Floor, Building 2, No.889, Yi Shan Rd., Shanghai, China 200233  
Tel: 021-6485-5560  
Fax: 021-6485-0313  
<http://www.holtek.com.cn>

**Holtek Semiconductor Inc. (Shenzhen Sales Office)**

5/F, Unit A, Productivity Building, Cross of Science M 3rd Road and Gaoxin M 2nd Road, Science Park,  
Nanshan District, Shenzhen, China 518057  
Tel: 0755-8616-9908, 8616-9308  
Fax: 0755-8616-9533

**Holtek Semiconductor Inc. (Beijing Sales Office)**

Suite 1721, Jinyu Tower, A129 West Xuan Wu Men Street, Xicheng District, Beijing, China 100031  
Tel: 010-66410030, 66417751, 66417752  
Fax: 010-66410125

**Holtek Semiconductor Inc. (Chengdu Sales Office)**

709, Building 3, Champagne Plaza, No.97 Dongda Street, Chengdu, Sichuan, China 610016  
Tel: 028-6653-6590  
Fax: 028-6653-6591

**Holmate Semiconductor, Inc. (North America Sales Office)**

46729 Fremont Blvd., Fremont, CA 94538  
Tel: 510-252-9880  
Fax: 510-252-9885  
<http://www.holmate.com>

Copyright © 2000 by HOLTEK SEMICONDUCTOR INC.

The information appearing in this Data Sheet is believed to be accurate at the time of publication. However, Holtek assumes no responsibility arising from the use of the specifications described. The applications mentioned herein are used solely for the purpose of illustration and Holtek makes no warranty or representation that such applications will be suitable without further modification, nor recommends the use of its products for application that may present a risk to human life due to malfunction or otherwise. Holtek's products are not authorized for use as critical components in life support devices or systems. Holtek reserves the right to alter its products without prior notification. For the most up-to-date information, please visit our web site at <http://www.holtek.com.tw>.