

Using the Buzzer Function on the HT49 MCU Series

D/N : HA0023E

Introduction

The HT49 series provide a pair of buzzer output pins known as BZ and $\overline{\text{BZ}}$, which are pin-shared with I/O pins PA0 and PA1. The choice of whether these pins are to function as I/O pins or as buzzer pins is determined by a configuration option. The buzzer output frequency extends over a range of $\text{source}/2^2 \sim \text{clock source}/2^9$ which cannot be changed once selected by configuration option.

After the buzzer output is chosen, it can be made to operate by clearing bits PA.0 and PA.1 (PA.0=0 & PA.1=0) at the same time. If bit PA.0 is set to 1, the buzzer outputs will be disabled. However if only PA.1 is set to 1, the buzzer will keep functioning but only on one pin.

The following table illustrates this:

PA.0	PA.1	Buzzer Output
1	1	No sound
0	0	Maximum volume \bar{n} both outputs active
0	1	Reduced volume \bar{n} only one pin active

Program Example

Hardware : connect the buzzer to pins PA.0 and PA.1

Configuration Options : PA0/1 choose BZ/ $\overline{\text{BZ}}$ output;

Bzfreq can choose the buzzer output frequency range from $\text{clock source}/2^2 \sim \text{clock source}/2^9$

Application Circuit

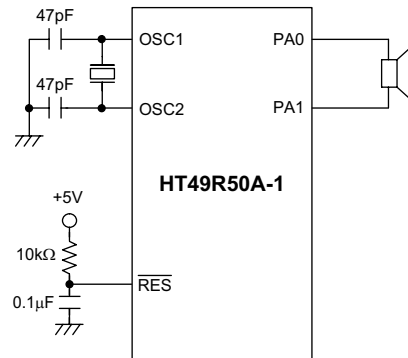

The following table shows the range of buzzer output frequencies with different clock sources and configuration options :

Buzzer Frequency	Clock Source				
	WDT (12kHz)	RTC (32.768kHz)	System Clock/4		
			1MHz/4	2MHz/4	4MHz/4
Clock Source/2 ²	3000.0000Hz	8192Hz	62500.00000Hz	125000.0000Hz	250000.000Hz
Clock Source/2 ³	1500.0000Hz	4096Hz	31250.00000Hz	62500.0000Hz	125000.000Hz
Clock Source/2 ⁴	750.0000Hz	2048Hz	15625.00000Hz	31250.0000Hz	62500.000Hz
Clock Source/2 ⁵	375.0000Hz	1024Hz	7812.50000Hz	15625.0000Hz	31250.000Hz
Clock Source/2 ⁶	187.5000Hz	512Hz	3906.25000Hz	7812.5000Hz	15625.000Hz
Clock Source/2 ⁷	93.7500Hz	216Hz	1953.12500Hz	3906.2500Hz	7812.500Hz
Clock Source/2 ⁸	46.8750Hz	128Hz	976.56260Hz	1953.1250Hz	3906.250Hz
Clock Source/2 ⁹	23.4375Hz	64Hz	488.28125Hz	976.5626Hz	1953.125Hz

Program list :

```

;-----
;FILE NAME : BUZZER.ASM
;Writer : Chin Juan
;Purpose : Introduction to using the HT49 series buzzer
;Hardware connection : connect the buzzer to pin PA.0 and PA.1
; ;
include ht49r50a-1.inc

code .section at 0h 'code'
org 00h
jmp start
;-----
data .section 'data'
count1 db ?
count2 db ?
;-----

```

```

main .section 'code'
    org     20h
    start:
        set     pa.0           ;set the buzzer outputs
        set     pa.1
        call    delay         ;delay
        call    delay
        clr     pa.1
        clr     pa.0         ;clear the buzzer output
        call    delay         ;delay
        call    delay
        set     pa.0         ;set the buzzer outputs
        set     pa.1
        call    delay
        call    delay         ;delay
        clr     pa.0         ;clear the pa.0 output
        call    delay         ;delay
        call    delay
        jmp     start

;-----
; ; ;
;delay subprogram
delay proc
    mov     a,0ffh
    mov     count1,a
    mov     count2,a
loop1 :
    sdz     count1
    jmp     loop1
    sdz     count2
    jmp     loop1
    ret
delay endp
end
;-----

```

- Program Instruction Flow

1. First, the buzzer output is disabled, wait for 1 second.
2. The buzzer will emit a sound with BZ and $\overline{\text{BZ}}$ both active for half a second and then stop for 1 second.
3. The buzzer will again emit a sound, but with a lower volume as only BZ will be active, for half a second and will then return to condition 1.