

HT48 & HT46 MCU I/O Port Application — Rolling LED Light Display

D/N : HA0009E

Introduction

The following note uses the HT48R30A-1 as an example to show an LED scanning light function. Each pin on PA port is connected to an LED via a 240Ω resistor to the power line to complete the circuit. Through this example it is possible to understand the basic usage of the input/output ports.

Circuit

PA0-PA7 are used as outputs and are connected via a resistor to control the LEDs using the RLC and RRC shift instructions. See the circuit below:

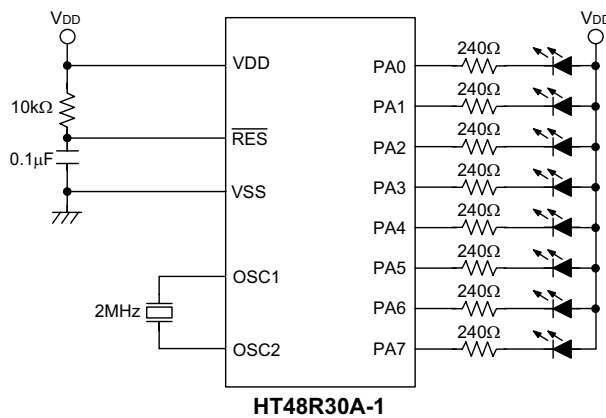

Program Example

```

#include                ht48R30A-1.inc
;-----
data .section        'data'            ;define data register
count1 db    ?                ;delay counter 0
count2 db    ?                ;delay counter 1
lamp  db    ?                ;light status register
;-----
code .section        at 0 'code'       ;program area
org 00h
jmp  start                ;main program start
start:
mov  a,0    ; (1)
mov  pac,a                ;PA setup as outputs
cpl  acc                ;ACC as 0FFH
mov  pa,a                ;set PA port initial status
mov  a,1    ; (2)
mov  lamp,a                ;send the light status initial
                                ;figure to the status register
llamp:
mov  a,lamp                ;lights shift to the left loop
                                ;send accumulator figure to the
                                ;light status register
cpl  acc                ;accumulator data is 0FFH
mov  pa,a                ;setup the illuminated LEDS and
the light status recorder
call delay ; (3)            ;call delay subprogram
clr  c                ;clear carry flag
rlc  lamp    ; (4)        ;light status register figure
                                ;shift to the left by 1 bit
sz   lamp                ;check if the light status
                                ;redorder is 0
jmp  llamp ; (5)            ;if not, continue with the loop
rrc  lamp    ; (6)        ;if yes, shift the light status
                                ;register to the right by 1 bit
rlamp:
                                ;the loop for light shift to the
                                ;right
mov  a,lamp                ;send light status register
                                ;figure to the accumulator
cpl  acc                ;accumulator as 0FFH
mov  pa,a                ;setup the illuminated light and
                                ;light status register
call delay                ;call delay subprogram
clr  c                ;clean carry flag
rrc  lamp    ; (7)        ;shift light status register
                                ;figure to the right by 1 bit
sz   lamp                ;check if the light status
                                ;register is 0
jmp  rlamp                ;if not, continue with the loop

```

```

                rlc    lamp                ;shift the light status register
                ;figure to the right
                jmp    llamp ; (8)        ;jump to left shifting loop
delay proc      ;delay subprogram
                mov    a,2fh
                mov    count1,a          ;define initial figure of the
                ;delay counter 1
                mov    count2,a          ;define initial figure of the
                ;delay counter 2
d1:
                sdz    count2            ;delay counter 2 decreases,
                ;check if the figure is 0
                jmp    d1                ;if not, jump to D1 loop
                sdz    count1            ;delay counter 1 decreases,
                ;check if the figure is 0
                jmp    d1                ;if not, jump to D1 loop
                ret                      ;subprogram return
delay endp      ;delay program over
                end                      ;main program over

```

Program Instruction

This small program will illuminate eight LEDs in order, first from the left to the right then from the right to the left. At the beginning, set the input/output port status (1). All the ports here are set as output and the PAC as 0. Then set the initial status of the output: the first PA as 0 and illuminate the first LED (2). To enable the LED to be seen, (3) set the delay subprogram. Through the light status recorder and accumulator, move the illuminated LED to the left by the left shift instruction (4). To test if all LEDs light up in order to the left, test if the light status recorder shows 0 (5). If yes, go back to the final left shift figure of the light status recorder (6). The program continues to control the LED to move to the right side. Use the right shift instruction RRC to control (7) and repeat the procedure. Finally check if the light status register shows 0. If yes, all LEDs have been illuminated while moving to the right side. The program jumps to the starting point and repeats the loop (8).