

# HOLTEK Touch Key IC Demo Board

## BS802B User Manual

### Components Description

#### ● Demo Board–Top Side

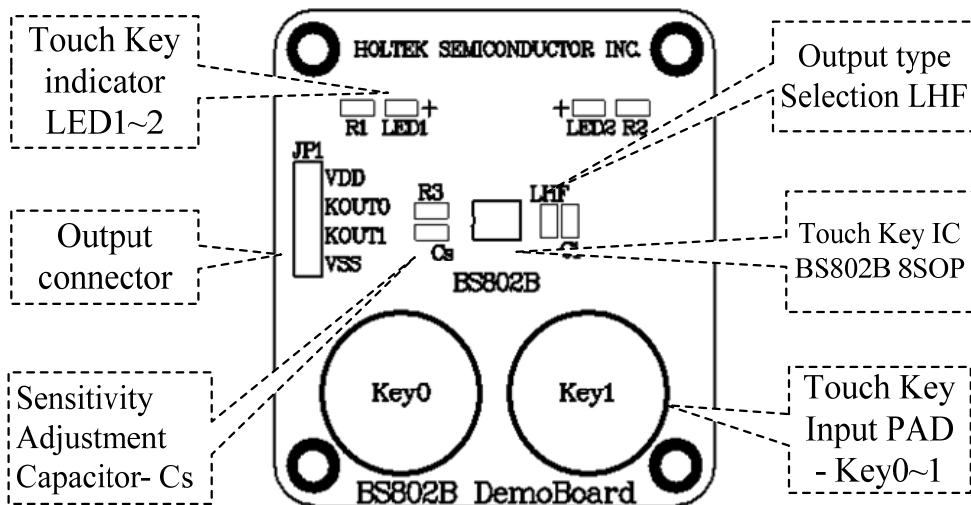

#### ● Demo Board–Bottom Side

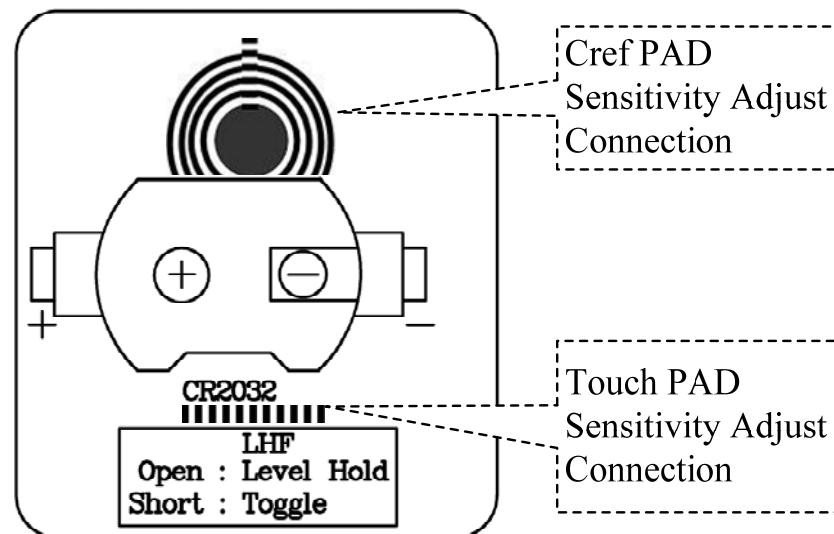

### Circuit Diagram

