

Flash Type Voice Demo Board

HT83F02

Characteristics

- Fully integrated RC oscillator
- External power amplifier -- HT82V739
- External SPI Flash Memory
- PWM / DAC output selection
- Digital volume control for PWM / DAC output
- Key select voice to play

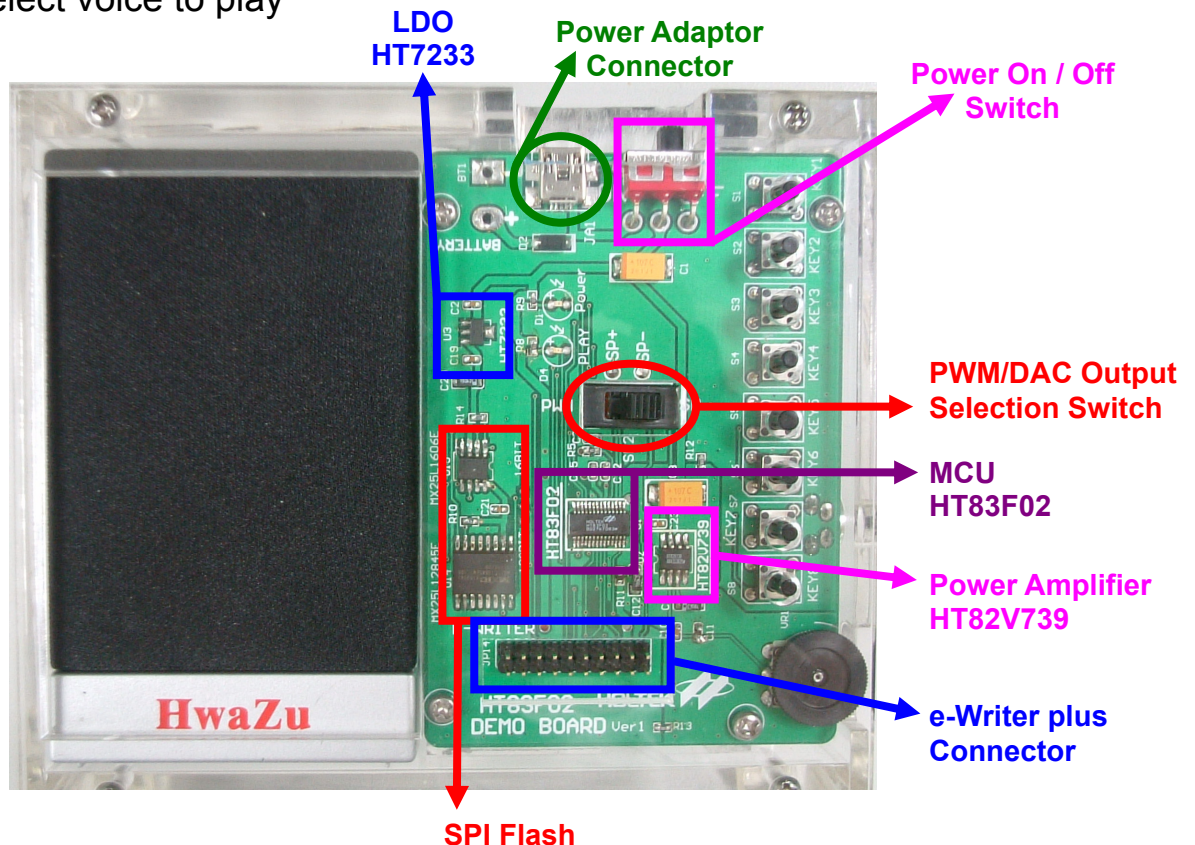

Operation Manual

- KEY1 : Play current voice
- KEY2 : Play previous
- KEY3 : Play next
- KEY4 : Volume up
- KEY5 : Volume down

Block Diagram

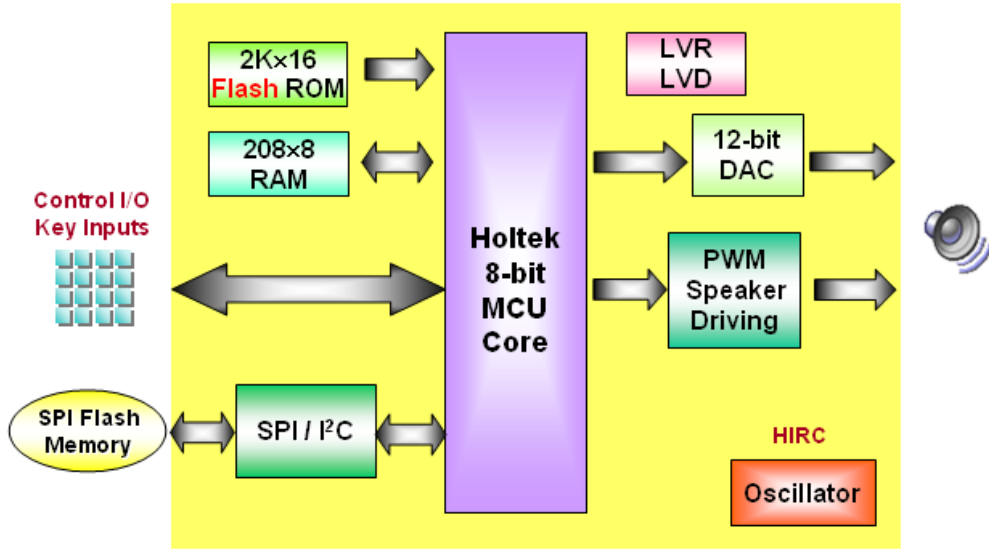

Application Circuit

