

Features

- Ultra-low supply current: 6 μ A typ.
- Input voltage: 12V max.
- Low temperature coefficient
- Voltage regulator output current: 30mA
- Voltage detector includes hysteresis
- High output voltage accuracy: \pm 3%
- Package: SOT89-5

Applications

- Battery powered system
- Communication equipment
- Audio/Video equipment
- Home application

General Description

The HT71AXXXX devices are CMOS technology voltage regulators which also include an internal voltage detector. The functions of the voltage regulators include a low dropout voltage, good output voltage accuracy as well as the benefits of ultra-low supply current. The inclusion of a voltage detector function in the same device

reduce what would normally be a two chip solution to a single chip solution resulting in reduced product costs. For maximum application flexibility, the voltage detector output is an N-channel open drain.

Selection Table

Part No.	Maximum Input Voltage	Regulator Voltage	Detector Voltage (V _{DF})	LDO Output Current (mA)	Typical Current Consumption (μ A)	Tolerance	Package
HT71A3324	12V	3.3V	2.4V	30	6	\pm 3%	SOT89-5
HT71A3327	12V	3.3V	2.7V	30	6	\pm 3%	SOT89-5
HT71A3344	12V	3.3V	4.4V	30	6	\pm 3%	SOT89-5
HT71A5024	12V	5.0V	2.4V	30	6	\pm 3%	SOT89-5
HT71A5027	12V	5.0V	2.7V	30	6	\pm 3%	SOT89-5
HT71A5033	12V	5.0V	3.3V	30	6	\pm 3%	SOT89-5
HT71A5042	12V	5.0V	4.2V	30	6	\pm 3%	SOT89-5
HT71A5044	12V	5.0V	4.4V	30	6	\pm 3%	SOT89-5

Block Diagram

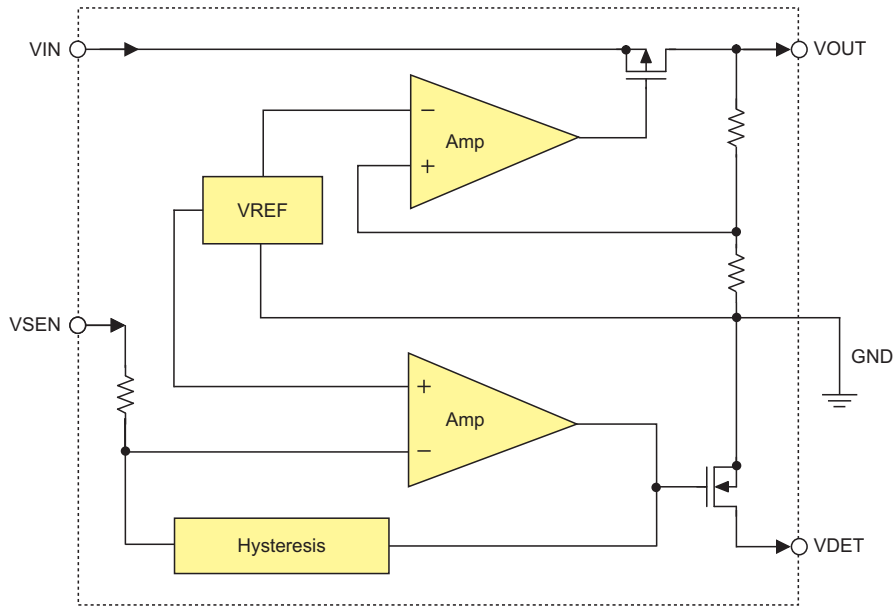

Pin Assignment

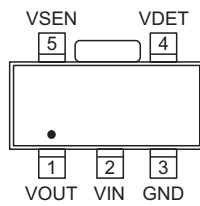

HT71Axxxx
SOT89-5-A
(Top View)

Pin Descriptions

Pin No.	Pin Name	Description
1	VOUT	Regulated Voltage Output Pin
2	VIN	Power Supply Input Pin
3	GND	Ground Pin
4	VDET	Voltage Detector Output Pin
5	VSEN	Voltage Detector Input Sense Pin

Absolute Maximum Ratings

Supply Voltage	-0.3V to 14.0V	VSEN Input Voltage Pin.....	-0.3V ~ $V_{IN}+0.3V$
VDET Output Voltage Pin	-0.3V ~ 14V	VOUT Output Voltage Pin.....	-0.3V ~ $V_{IN}+0.3V$
Power Consumption	500mW	Storage Temperature	-50°C to +125°C
Operating Temperature	-40°C to +85°C		

Note: These are stress ratings only. Stresses exceeding the range specified under "Absolute Maximum Ratings" may cause substantial damage to the device. Functional operation of this device at other conditions beyond those listed in the specification is not implied and prolonged exposure to extreme conditions may affect device reliability.

Electrical Characteristics
 $V_{IN}=V_{SEN}=V_{OUT}+2.0V$, unless otherwise specified, $T_a=25^\circ C$

Symbol	Parameter	Test Conditions	Min.	Typ.	Max.	Unit
V_{IN}	Operating Input Voltage	—	—	—	12	V
I_{SS}	Supply Current	$V_{OUT}>V_{DET}$, $V_{IN}=V_{SEN}=V_{OUT}+2$ $V_{OUT}<V_{DET}$, $V_{IN}=V_{SEN}=V_{DET}+2$	—	6	12	μA
Voltage Regulator						
V_O	Output Voltage	$V_{IN}=V_{OUT}+2$, $I_{OUT}=10mA$	$V_{OUT}-3\%$	V_{OUT}	$V_{OUT}+3\%$	V
I_{OUT}	Output Current	$V_{IN}=V_{OUT}+2$, $\Delta V_O=3\%$	20	30	—	mA
ΔV_O	Load Regulation	$V_{IN}=V_{OUT}+2$, $1mA \leq I_{OUT} \leq 30mA$	—	60	100	mV
ΔV_{DIF}	Dropout Voltage	$\Delta V_O=2\%$, $I_{OUT}=1mA$	—	100	—	mV
$\frac{\Delta V_O}{\Delta V_{IN} \times V_O}$	Line Regulation	$I_{OUT}=1mA$, $V_{OUT}+1 \leq V_{IN} \leq 12V$	—	0.2	—	%/V
$\frac{\Delta V_O}{\Delta T_a}$	Temperature Coefficient	$I_{OUT}=10mA$, $-40^\circ C \leq T_a \leq +85^\circ C$	—	± 0.75	—	mV/ $^\circ C$
Voltage Detector						
V_D	Detection Voltage	High to Low	$V_{DF}-3\%$		$V_{DF}+3\%$	V
V_{HYS}	Hysteresis Width	—	$V_{DF} \times 0.02$	$V_{DF} \times 0.05$	$V_{DF} \times 0.10$	V
I_{OL}	Output Sink Current	$V_{IN}=V_{SEN}=2V$, $V_{DET}=0.2V$	0.5	1.0	—	mA
$\frac{\Delta V_D}{\Delta T_a}$	Temperature Coefficient	$-40^\circ C \leq T_a \leq +85^\circ C$	—	± 0.75	—	mV/ $^\circ C$

Note: The V_{DF} is the detector voltage of the device. For more detailed information of the detector voltage for different devices, refer to the preceding Selection Table.

Functional Description

The HT71Axxxx devices are a series of combined regulator and detector devices. The voltage regulator part of the devices have very low dropout voltage and low current consumption and can supply up to 30mA of output current. The output voltage is available in both 3.3V and 5V types. An input voltage of up to 12V can be accepted on their input pin.

The voltage detector part of the devices can detect an externally supplied voltage on its sense pin. This externally supplied voltage will be compared with a fixed internal reference voltage which can have a range of fixed voltages ranging from 2.4V to 4.4V. When the external

sense voltage falls below the detect voltage the detector output will switch low. The detector output is an open drain NMOS type therefore users must connect an external pull-high resistor for correct operation. The voltage detectors consist of a high-precision and low power consumption standard voltage source as well as a comparator, hysteresis circuit, and an output driver. CMOS technology ensures low power consumption. Although designed primarily as fixed voltage detectors, these devices can be used with external components to detect user specified threshold voltages.

Application Circuits

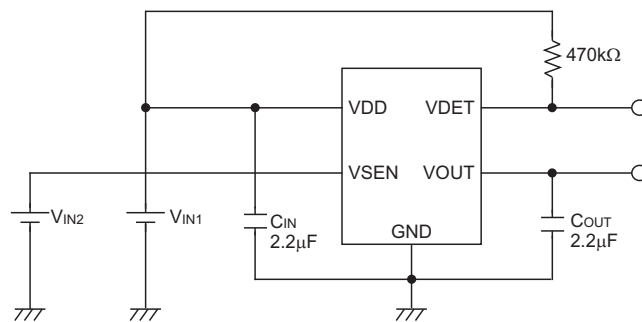

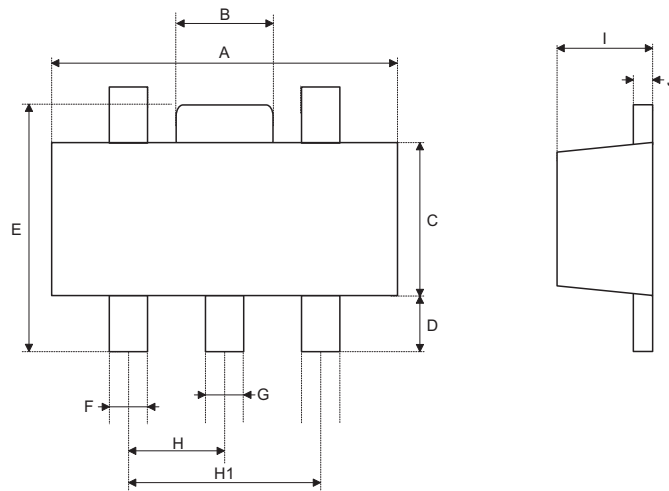
Package Information
5-pin SOT89 Outline Dimensions

Symbol	Dimensions in inch		
	Min.	Nom.	Max.
A	0.173	—	0.181
B	0.055	—	0.071
C	0.091	—	0.102
D	0.035	—	0.043
E	0.155	—	0.167
F	0.013	—	0.020
G	0.014	—	0.022
H	—	1.52	—
H1	0.114	—	0.122
I	0.055	—	0.063
J	0.014	—	0.017

Symbol	Dimensions in mm		
	Min.	Nom.	Max.
A	4.39	—	4.60
B	1.40	—	1.80
C	2.31	—	2.59
D	0.89	—	1.09
E	3.94	—	4.24
F	0.33	—	0.51
G	0.36	—	0.56
H	—	1.52	—
H1	2.90	—	3.10
I	1.40	—	1.60
J	0.36	—	0.43

Holtek Semiconductor Inc. (Headquarters)

No.3, Creation Rd. II, Science Park, Hsinchu, Taiwan
Tel: 886-3-563-1999
Fax: 886-3-563-1189
<http://www.holtek.com.tw>

Holtek Semiconductor Inc. (Taipei Sales Office)

4F-2, No. 3-2, YuanQu St., Nankang Software Park, Taipei 115, Taiwan
Tel: 886-2-2655-7070
Fax: 886-2-2655-7373
Fax: 886-2-2655-7383 (International sales hotline)

Holtek Semiconductor Inc. (Shenzhen Sales Office)

5F, Unit A, Productivity Building, No.5 Gaoxin M 2nd Road, Nanshan District, Shenzhen, China 518057
Tel: 86-755-8616-9908, 86-755-8616-9308
Fax: 86-755-8616-9722

Holtek Semiconductor (USA), Inc. (North America Sales Office)

46729 Fremont Blvd., Fremont, CA 94538
Tel: 1-510-252-9880
Fax: 1-510-252-9885
<http://www.holtek.com>

Copyright © 2009 by HOLTEK SEMICONDUCTOR INC.

The information appearing in this Data Sheet is believed to be accurate at the time of publication. However, Holtek assumes no responsibility arising from the use of the specifications described. The applications mentioned herein are used solely for the purpose of illustration and Holtek makes no warranty or representation that such applications will be suitable without further modification, nor recommends the use of its products for application that may present a risk to human life due to malfunction or otherwise. Holtek's products are not authorized for use as critical components in life support devices or systems. Holtek reserves the right to alter its products without prior notification. For the most up-to-date information, please visit our web site at <http://www.holtek.com.tw>.